



Full Circle

THE INDEPENDENT MAGAZINE FOR THE UBUNTU LINUX COMMUNITY

ISSUE #114 - October 2016



system76
INTERVIEW



BOOK REVIEW

ELECTRONICS FOR KIDS

PLAY WITH CIRCUITS AND EXPERIMENT WITH ELECTRICITY!

BY BYRON BYRD PAUL



STOP YOUR CPU OVERHEATING BY USING INXI AND STOPPING ROGUE PROCESSES

Photo: garhol (Flickr.com)



HowTo



Python p.17



Stop CPU Overheating p.19

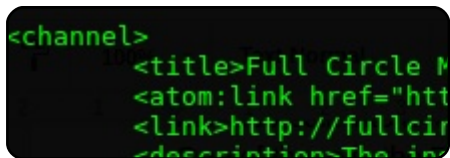

Program With FreePascal p.21



p.XX

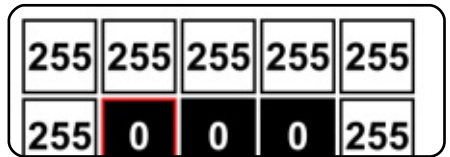

Inkscape p.25



Graphics



Full Circle

THE INDEPENDENT MAGAZINE FOR THE UBUNTU LINUX COMMUNITY

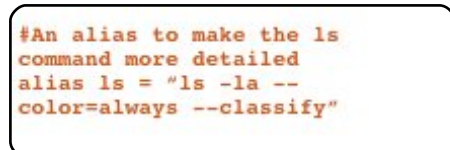

Command & Conquer p.16

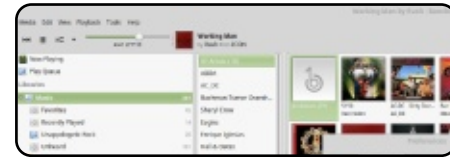

Linux Labs p.30



Book Review p.33

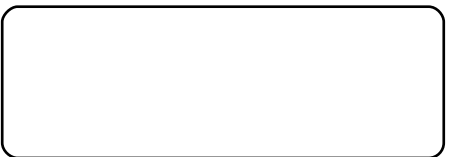

Q&A p.41

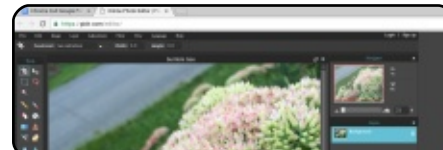

Chrome Cult p.28



Ubuntu Devices p.32



Letters p.37



Interview: System76 p.43



Linux News p.04



Linux Loopback p.32

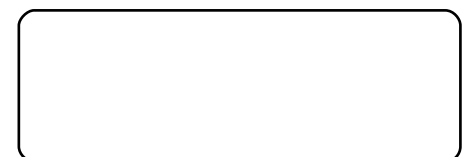

My Opinion p.34



KODI Room p.39



Ubuntu Games p.46



The articles contained in this magazine are released under the Creative Commons Attribution-Share Alike 3.0 Unported license. This means you can adapt, copy, distribute and transmit the articles but only under the following conditions: you must attribute the work to the original author in some way (at least a name, email or URL) and to this magazine by name ('Full Circle Magazine') and the URL www.fullcirclemagazine.org (but not attribute the article(s) in any way that suggests that they endorse you or your use of the work). If you alter, transform, or build upon this work, you must distribute the resulting work under the same, similar or a compatible license.

Full Circle magazine is entirely independent of Canonical, the sponsor of the Ubuntu projects, and the views and opinions in the magazine should in no way be assumed to have Canonical endorsement.



WELCOME TO ANOTHER ISSUE OF FULL CIRCLE.

The usual suspects are here with FreePascal, Inkscape and Python. The third HowTo is one on using Inxi to stop your CPU from overheating. Obviously, it should go without saying, if your CPU is always overheating then your machine has a serious problem that should be looked at. But if overheating happens every once in a while you can sometimes catch it and monitor it with something like Inxi. Then use some careful terminal commands to end processes that are thought to cause overheating.

Charles has a new column this month: KODI Room. As you may (or may not) know, Charles authored a book on KODI (back when it was still called XBMC) so he definitely loves KODI. Each month he'll present some hints, tips, and whatnot to help you cut the cord and use a KODI box for either viewing your existing library, or getting some (legitimate!) free TV and movies.

I'm not sure if there'll be a new interview every month, but certainly this month we have an interview with Ryan Sipes from System76. You might remember Ryan from the Mycroft AI project. You emailed me your questions, and I compiled them into a list. So, let's do it again! Wire (the audio/video/text messenger) was recently released on Linux. Do you have a question for the developers? Again, email it to me, and I'll pass them along. Hopefully, we'll have that interview next month.

If you're in the market for a self-hosted cloud solution then you might want to take a look at the Nextcloud box that I've mentioned in my Ubuntu Devices column. I've no device to review, unfortunately, but it uses a Raspberry Pi 2 (running Ubuntu) and a hard drive. A neat idea to become your own Dropbox/Owncloud.

All the best, and keep in touch!

Ronnie

ronnie@fullcirclemagazine.org



This magazine was created using :



Find Full Circle on:



goo.gl/FRTML



facebook.com/fullcirclemagazine



twitter.com/#!/fullcirclemag



<http://issuu.com/fullcirclemagazine>



<http://www.magzter.com/publishers/Full-Circle>

Weekly News:



<http://fullcirclemagazine.org/feed/podcast>



<http://www.stitcher.com/s?fid=85347&refid=stpr>



<http://tunein.com/radio/Full-Circle-Weekly-News-p855064/>

THE FULL CIRCLE WEEKLY NEWS



A short podcast (<10min) with just the news. No chit-chat. No time wasting. Just the latest FOSS/Linux/Ubuntu news.

RSS:
<http://fullcirclemagazine.org/feed/podcast>



NMAP 7.30 SECURITY SCANNER ADDS 12 NEW IPV6 OS FINGERPRINTS, 7 NSE SCRIPTS

The Nmap developers announced the release of Nmap 7.30, the latest stable version of the free, open source and cross-platform security scanner and network mapper software.

Nmap 7.30 is a major release that adds numerous new features and improvements, among which we can mention twelve new IPv6 OS fingerprints and seven NSE (Nmap Scripting Engine) scripts that have been submitted by various developers. There are now a total of 541 NSE scripts included in Nmap.

Moreover, the new Npcap Windows packet capturing driver and library has been updated to version 0.10r2, a release that includes numerous bug fixes, new match lines and service probes were implemented for Tridium Fox,

MQTT, DTLS, ProConOS, IPMI-RMCP, and PCWorx, and the output filtering has been improved.

The new NSE scripts are coap-resources and mqtt-subscribe by Mak Kolybabi, pcworx-info and fox-info by Stephen Hilt, as well as ipmi-brute, ipmi-cipher-zero, and ipmi-version by Claudiu Perta. More details about all the NSE scripts included in the Nmap 7.30 release can be found at <https://nmap.org/nosedoc/>.

Source:
<http://news.softpedia.com/news/nmap-7-30-security-scanner-adds-12-new-ipv6-os-fingerprints-7-nse-scripts-508803.shtml>

UBUNTU'S SHUTTLEWORTH EXPLAINS WHY NOT ALL CONTAINERS ARE THE SAME

Mark Shuttleworth, the founder of Ubuntu Linux, was an early backer of OpenStack as well as containers. This week, Shuttleworth's company Canonical

announced new commercial support for Kubernetes, which is a widely deployed container orchestration and management engine.

In an interview with Datamation Shuttleworth emphasized that it's important to understand the different use cases for containers and what the different types of container systems are all about.

"There are going to be different types of container co-ordination systems," Shuttleworth said. "There will trucks, tractors and cars."

Shuttleworth emphasized that in his view, he doesn't expect there to only be one way to manage container processes. For Shuttleworth, the Docker world is all about co-ordinating processes, while the OpenStack world is about co-ordinating machines.

"Kubernetes is really stepping up to lead the hyper-elastic, on-demand, operational story," Shuttleworth said.

With Kubernetes the story is also about stateless applications, essentially things that are dealing with single process requests, or requests related to a specific customer. Shuttleworth expect that databases will run outside of Kubernetes control and that Kubernetes will focus on the hyper-elastic application code.

Source:

<http://www.datamation.com/open-source/ubuntus-shuttleworth-explains-why-not-all-containers-are-the-same.html>

LINUX 4.8 KERNEL WILL SUPPORT NEWER HARDWARE, INCLUDING YOUR MICROSOFT SURFACE 3

After going through eight different release candidates, Linux engineer Linus Torvalds officially announced the release of the Linux 4.8 kernel branch on Monday, marking the end of a long and arduous testing cycle and the beginning of a new one.

The release of the 4.8 kernel

branch comes just in time for Ubuntu 16.10, which is slated to release later in October and will be one of the first major Linux distros to use the brand new mainline kernel. Other distributions which use rolling releases, should see the 4.8 kernel incorporated soon, which is good news for anyone running Linux on newer hardware.

The latest 4.8 kernel boasts wide support for newer hardware, including improvements to existing drivers — most notably for GPUs, networking and a handful of CPU architectures.

Of particular note for this most recent Linux kernel, is the inclusion of support for the Microsoft Surface 3 touchscreen which opens up a branch of hardware previously closed to Linux users. Now you will have an easier time running your favorite distro on a Surface Book or Surface Pro.

Source:

<http://www.digitaltrends.com/computing/linux-kernel-48-released/>

MELLANOX DEPLOYS STANDARD LINUX OPERATING SYSTEMS OVER ETHERNET SWITCHES

Mellanox announced the availability of standard Linux kernel driver for the company Open Ethernet, Spectrum switch platforms. Developed within the large Linux community, the new driver enables standard Linux Operating Systems and off-the-shelf Linux-based applications to operate on the switch, including L2 and L3 switching. Open Ethernet provides data centers with the flexibility to choose the best hardware platform and the best software platform, resulting in optimized data center performance and higher return on investment.

Mellanox Technologies' Open Ethernet switch platforms, which currently support multiple operating systems, such as Cumulus Linux, MLNX-OS and more, now also support any native Linux operating system. Mellanox is the first Ethernet switch solution provider to offer such a variety of options for its Spectrum Open

Ethernet switch portfolio.

Source:

<http://insidehpc.com/2016/10/open-ethernet-gains-further-momentum-with-deployment-of-standard-linux-operating-systems-over-ethernet-switches/>

NETWORKMANAGER 1.4.2 RELEASED FOR GNU/LINUX DISTROS WITH VARIOUS IMPROVEMENTS

Beniamino Galvani announced a new stable release of the NetworkManager network configuration tool suite for GNU/Linux operating systems, the second for the latest 1.4 series.

NetworkManager 1.4.2 is now the most advanced stable version of the popular software project used by default in almost all GNU/Linux distributions, and it comes five weeks after the release of NetworkManager 1.4.0, which was a major milestone that brought numerous exciting new features and improvements.

However, NetworkManager

1.4.2 is a bugfix release, which means that it attempts to resolve many of the issues reported by users since NetworkManager 1.4.0. According to the release notes, the new version improves the bash autocompletion and restores the checking of JSON syntax when building the software with Jansson support.

Moreover, NetworkManager 1.4.2 addresses a regression discovered in libnm library's serialization of empty "cloned-mac-address" property, and fixes a race condition that occurred in the communication between the Dynamic Host Configuration Protocol (DHCP) helper and NetworkManager, causing loss of events.

Source:

<http://news.softpedia.com/news/networkmanager-1-4-2-released-for-gnu-linux-distros-with-various-improvements-508860.shtml>

THE LINUX FOUNDATION'S OPEN COMPLIANCE INITIATIVE RELEASES NEW SPDX SPECIFICATION

The SPDX® Project, hosted by The Linux Foundation®, today is announcing the release of version 2.1 of its Software Package Data Exchange (SPDX) specification. SPDX 2.1 standardizes the inclusion of additional data in generated files, as well as providing a syntax for accurate tagging of source files with SPDX license list identifiers.

According to The 2016 North Bridge & Black Duck Future of Open Source Study, 90 percent of companies rely on open source for improved efficiency, innovation and interoperability, yet only half of those companies have a formal management process for the code they rely upon. The SPDX specification helps facilitate compliance with free and open source software licenses by providing a uniform way license information is shared across the software supply chain. The effort unites more than 20 organizations -- software, systems and tool vendors, foundations and systems integrators -- to create a specification for software package data exchange formats.

Source:

<http://www.marketwired.com/press-release/the-linux-foundations-open-compliance-initiative-releases-new-spdx-specification-2163569.htm>

DELL XPS 13 LAPTOPS WITH KABY LAKE NOW AVAILABLE FOR \$800 AND UP (WINDOWS AND UBUNTU OPTIONS)

Dell's 2016 line of XPS 13 thin and light laptops are now available. The new models feature Intel Kaby Lake processors and slightly bigger batteries than their predecessors.

But otherwise the new Dell XPS 13 laptops are a lot like the models Dell has released for the past few years: they're thin, they're light, they have affordable starting prices, and there are even a few models that come with Ubuntu Linux instead of Windows 10.

The new XPS 13 laptops were unveiled a few weeks ago, and now they're available from Dell.com for \$800 and up.

The laptop measures about 0.6 inches thick and weighs about 2.7 pounds, features a carbon fiber and aluminum body, and has super-slim bezels, allowing Dell to put a 13.3 inch display on a notebook that's closer to the size you'd expect from a 12 inch model.

An entry-level model features a 1920 x 1080 pixel display, an Intel Core i3-7100U processor, 4GB of RAM, 128GB of solid state storage, and a 60 Wh battery.

But Dell also offers models with up to a Core i7-7500U CPU, up to 16GB of RAM, and up to 512GB of solid state storage. Some higher-priced models also have 3200 x 1800 pixel touchscreen displays.

Each laptop has two USB 3.0 ports, a Thunderbolt 3/USB 3.1 Type-C port, an SD card reader, and a headset jack as well as a 720p webcam, 802.11ac WiFi, and Bluetooth 4.1.

Source:

<http://liliputing.com/2016/10/dell-xps-13-laptops-with-kaby-lake-now-available-for-800-and-up-windows-and-ubuntu-options.html>

KDE NEON 5.8 USER EDITION LINUX OS OFFERS THE LATEST KDE PLASMA 5.8 LTS DESKTOP

The KDE Neon development team announced the release of the KDE Neon 5.8 User Edition GNU/Linux distribution with the recently released KDE Plasma 5.8 LTS desktop environment.

If you're using the KDE Neon operating system on your personal computer, you need to update your installation to receive the new KDE Plasma 5.8 LTS packages and enjoy a better, more stable and more reliable KDE Plasma 5 desktop environment that will get extended, long-term support until April 2018.

There are many cool new features shipping with the KDE Plasma 5.8 LTS desktop environment, which is a recommended upgrade for anyone using KDE Plasma 5.7 or a previous release. Also, for the first time in the history of KDE Plasma 5, the development team recommends it for everyday use to all Linux users.

Source:

<http://news.softpedia.com/news/kde-neon-5-8-user-edition-linux-os-offers-the-latest-kde-plasma-5-8-lts-desktop-508964.shtml>

TESLA VEHICLES TO GET A MUCH-NEEDED UPDATED BROWSER WITH NEW LINUX OS IN DECEMBER, SAYS MUSK

There are plenty of useful and well-thought-out features on Tesla's 17-in touchscreen, but the internet browser is not one of them. For years now, we have been used to high-speed internet browsing on our laptops, desktop and now even on phones, but Tesla's browser is so slow that it feels like it's from another era.

Model S and X owners have been asking for an update to the browser for a long time and unfortunately, it didn't come with the recent 8.0 update, but Tesla CEO Elon Musk said that it will with an upcoming update, which will likely be in December.

Tesla's operating system is built

on a modified version of Linux Ubuntu. Musk says that Tesla aims to upgrade the Linux OS to 4.4 in Tesla vehicles in December. That's when he expects they will be able to update the browser.

Source:

<https://electrek.co/2016/10/06/tesla-updated-browser-linux-os-december-says-musk/>

REGISTER NOW FOR LIBREPLANET 2017: "THE ROOTS OF FREEDOM" MARCH 25-26, 2017 IN BOSTON, MA

Clear your calendars for the last weekend of March 2017! Registration for LibrePlanet is now open. The conference will be held March 25-26, 2017, in the Boston area.

Last year, over 350 people participated in LibrePlanet, traveling from 11 countries and 28 U.S. states. And guess what? Students and FSF members attend LibrePlanet gratis. Not a member? Join today to register gratis, or register at our non-member rate.

This year's theme is "The Roots of Freedom." Some talks at this year's conference will look back at the historical "roots" of the free software movement, including the Four Freedoms, the GNU General Public License and copyleft, and the focus on strong security and privacy protections. Others will look at the movement's strong, foundational "roots" -- and the exciting developments that grow from them in education, business, activism, and the arts.

Source:

<https://www.fsf.org/blogs/community/register-now-for-libreplanet-2017-the-roots-of-freedom-march-25-26-2017-in-boston-ma>

UBUNTU ON INTEL ATOM MINI PCs (LINUXIUM'S BUILDS FOR BAY TRAIL AND CHERRY TRAIL COMPUTERS)

Over the past few years a number of companies have released small desktop computers with Intel Atom processors. Some ship with Windows software. Some have Linux. And others have no operating system at all.

Want to install your own operating system? If you're using Windows that shouldn't be too hard. But Linux may be another story, since many GNU/Linux-based operating systems lack some of the wireless or HDMI/audio features you may need.

But developer Linuxium (Ian Morrison) has been releasing patched builds of Ubuntu Linux for tiny, Atom-powered computers like the Intel Compute Stick for a while. Now he has gathered a bunch of his builds in one place, making it easy to install Ubuntu on most desktop computers with Intel Bay Trail or Cherry Trail processors.

In addition to Ubuntu, there are downloads available for Lubuntu, Xubuntu, Kubuntu, Ubuntu GNOME, and Ubuntu MATE (which all share a common core, but which have different desktop environments).

Source:
<http://liliputing.com/2016/10/ubuntu-intel-atom-mini-pcs-linuxiums-builds-bay-trail-cherry-trail-computers.html>

DEBEX GNOME LIVE DVD RELEASED WITH GNOME 3.22, MATE 1.16, AND LINUX KERNEL 4.8

After announcing the release of DebEX KDE Live DVD Build 161001, GNU/Linux developer Arne Exton informs about the availability of a new build of his DebEX GNOME Live DVD.

Borrowing packages from the software repositories of both Debian GNU/Linux 9 "Stretch" (Testing) and Debian Sid (Unstable) operating systems, DebEX GNOME Live DVD Build 161007 comes with a lot of goodies for fans of the GNOME 3 and MATE (GNOME 2 fork) desktop environments, as it upgrades them to the latest GNOME 3.22 and MATE 1.16 releases respectively.

The new DebEX GNOME Live DVD release, which launched officially on the day of October 7, 2016, ships with the recently released Linux 4.8 kernel, which was tweaked and optimized, as well as injected with additional drivers to support more hardware components. Therefore, DebEX

GNOME Live DVD Build 161007 uses Arne Exton's special kernel 4.8.0-21-exton.

Source:
<http://news.softpedia.com/news/debex-gnome-live-dvd-released-with-gnome-3-22-mate-1-16-and-linux-kernel-4-8-509080.shtml>

UBUNTU ON LENOVO THINKPAD P50

The Lenovo ThinkPad P50 laptop with the components described on www.ubuntu.com/certification/hardware/201512-20418/ has been awarded the status of certified pre-install for Ubuntu.

The system is available in some regions with a special image of Ubuntu pre-installed by the manufacturer. It takes advantage of the hardware features for this system and may include additional software. You should check when buying the system whether this is an option.

Standard images of Ubuntu may not work at all on the system or may not work well, though

Canonical and computer manufacturers will try to certify the system with future standard releases of Ubuntu.

Source:
<https://www.ubuntu.com/certification/hardware/201512-20418/>

SOLUS GETS LINUX KERNEL 4.8.1, LIBREOFFICE 5.2.2, AND RADEON VULKAN DRIVER

Solus developer Joshua Strobl announced the 37th installation of This Week in Solus (TWiS) newsletter with the latest news about what happened in the Solus world during this week.

First of all, it looks like Solus is the first stable (rolling) GNU/Linux operating system to offer the recently released Linux 4.8.1 kernel, which the Solus team garnished with a new layer of security to protect you against 0-day exploits, support for native sockets over a hypervisor, support for Microsoft Surface Pro 3's touch controller, as well as support for the power button on the new Dell

XPS 13 Developer Edition laptop.

We're all writing something a Word editor or editing XML documents in Excel, so an office suite is something that must be installed by default in any operating system. The popular LibreOffice has been updated recently to version 5.2.2, the second maintenance version to the latest stable series, which now is included in the main software repositories of Solus.

Among other goodies that landed in Solus during this week, there's the enablement of the systemd user session by default, providing user service management, as well as the open-source AMD Radeon Vulkan graphics driver, along with the OpenSWR driver (Intel AVX2 - Advanced Vector Extensions).

Source:

<http://news.softpedia.com/news/solus-gets-linux-kernel-4-8-1-libreoffice-5-2-2-and-radeon-vulkan-driver-509094.shtml>

LINUXIUM RELEASES UBUNTU BUILDS FOR SMALL PCs POWERED BY INTEL

Developer Linuxium has released different Ubuntu builds for small Intel-based PCs that are based on Bay Trail and Cherry Trail SOCs. Thanks to kernel patches, the users won't face problems in HDMI audio, Wi-Fi, Bluetooth etc. while using Linux operating systems on such device.

If you own a small desktop computer powered by Intel Atom processor that are based on Bay Trail and Cherry Trail SOCs, running Windows OS on them doesn't pose any problem.

However, installing Linux distributions is a different story. Attempting to do so results in HDMI audio, Wi-Fi and Bluetooth problems etc.

To address this situation, Linuxium-developer Ian Morrison-has released Ubuntu builds for the mini PCs. On his blog, he writes that Ubuntu is well suited for Mini PCs as its different flavors provide the option to run a lightweight Linux-based OS.

He has created ISO images specifically for Intel Compute Stick. These images also work with other Atom Bay Trail and Cherry Trail processors.

Linuxium has combined the source code and recent patches to port them with Ubuntu kernel source. This has allowed him to provide a fully functional HDMI audio, Bluetooth, and Wi-Fi experience.

Apart from Ubuntu, users can also download images for Lubuntu, Kubuntu, Xubuntu, Ubuntu GNOME, and Ubuntu MATE.

Source:

<https://fossbytes.com/linuxium-releases-ubuntu-builds-intel-atom-based-mini-pcs/>

DEBEX BAREBONE LIVE DVD FEATURES XFCE 4.12.1 AND KERNEL 4.8

DebEX Barebone Live DVD is the third and last edition of the Debian-based DebEX operating system, and it looks like the build, version 161009, is here today,

October 9, 2016, pre-installed with all the latest GNU/Linux technologies and open source software projects, including the recently released Linux 4.8 kernel.

Built around the lightweight and highly customizable Xfce 4.12.1 desktop environment, DebEX Barebone Live DVD Build 161009 is based on the Debian GNU/Linux 9"Stretch" (Testing) and Debian Sid (Unstable) operating systems, just like the DebEX GNOME Live DVD. Of course, all the included packages are at their latest versions as of October 9.

Among some of the most interesting things included in the DebEX Barebone Live DVD Build 161009, we can mention the Nvidia 370.28 proprietary video driver for owners of Nvidia graphics cards, the Google Chrome web browser for those who want to watch TV shows and movies on the Netflix video streaming platform, and the Tor Browser for those who want to browse the Internet anonymously.

Source:

<http://news.softpedia.com/news/debian-based-debex-barebone-live-dvd-features-xfce-4-12-1-and-linux-kernel-4-8-509109.shtml>

LINUX KERNEL 4.7.7 HAS NFS IMPROVEMENTS, UPDATED WIRELESS AND INFINIBAND DRIVERS

After announcing the imminent release of Linux kernel 4.8.1, as well as the availability of Linux kernel 4.4.24 LTS, Greg Kroah-Hartman has informed the community about the launch of the seventh maintenance update to the Linux 4.7 kernel series.

Linux kernel 4.7.7 is now here for those of you who are still using the Linux 4.7 kernel branch in your GNU/Linux distributions, and according to the appended shortlog and the diff from the previous maintenance update, namely Linux kernel 4.7.6, the new version changes a total of 142 files, with 852 insertions and 490 deletions, which means that it's a pretty hefty release.

As mentioned before, Linux kernel 4.7.7 comes with many improvements, including a large number of updated wireless drivers (Broadcom, Intel, Marvell), as well as enhancements for

Ethernet (Intel), InfiniBand, MMC, MTD, MD, GPU (Radeon, Nouveau), DMA, I2C, GPIO, hwmon, IRQ Chip, NFC, PCMCIA, PINCTRL, SCSI, USB, and Watchdog. It also adds minor enhancements to the NFS and Ceph filesystems.

Moreover, the Linux 4.7.7 kernel brings an updated networking stack with B.A.T.M.A.N. Advanced, Bluetooth, mac80211, and SunRPC changes, an updated sound stack with Intel Skylake, HDA, and OMAP improvements, various fixes to the ARM, ARM64 (AArch64), AVR32, MIPS, PowerPC (PPC), x86, and Tile hardware architectures, as well as the usual core kernel and mm bugfixes.

Source: <http://news.softpedia.com/news/linux-kernel-4-7-7-has-nfs-improvements-updated-wireless-and-infiniband-drivers-509101.shtml>

SYSTEM76 LAUNCHES NEW UBUNTU-POWERED LEMUR LAPTOP WITH INTEL KABY LAKE CPUS

System76, a US-based computer manufacturer specializing in the distribution of notebooks, desktop and server computers powered by the Ubuntu Linux operating system, launched a new model of their famous Lemur laptop.

If you're currently enjoying your excellent Lemur laptop from System76, you should know that a better version is now available, featuring 7th generation Intel i3-7100U or i7-7500U Kaby Lake processors that provide stunning performance and much faster Intel HD 620 graphics. The new Lemur laptop also features up to 32GB of dual-channel DDR4 RAM.

Connectivity-wise, the new Lemur laptop ships with a brand new USB Type-C port, along with one USB 3.0 and one USB 2.0 port, a built-in SD card reader, Gigabit Ethernet, Intel Wireless-AC, Bluetooth, an HDMI 1.4a port, as well as a VGA port. It also features M.2 SSD support for up to 4.5TB storage, stereo speakers and mic, headphone and mic jacks, Kensington lock, and a 720p (1280×960) HD webcam.

As expected, the laptop comes pre-installed with the latest Ubuntu 16.04.1 LTS (Xenial Xerus) operating system from Canonical, which will receive maintenance updates for five years, until April 2021.

Source: <http://news.softpedia.com/news/system76-launches-new-ubuntu-powered-lemur-laptop-with-intel-kaby-lake-cpus-509194.shtml>

LINUS TORVALDS: "LINUX KERNEL 5.0 WILL BE RELEASED WHEN WE HIT 6 MILLION GIT OBJECTS"

Linux creator Linus Torvalds has shared the news that we are half-way between Linux 4.0 and 5.0 as the Git object database has crossed the 5 million object mark. Some of you might be knowing that major version transition happens at every two million objects in the database. So, after 1 more million Git objects, we can expect the release of Linux kernel 5.0 in 2017.

Earlier this month, Linus

Torvalds announced the release of Linux 4.8 kernel. It'll be followed by Linux 4.9, which will be the next LTS kernel. Some of you might be wondering about the release date of Linux 5.0 kernel. While Linux creator Linus Torvalds hasn't set an official date, he has given a hint.

In a recent Google+ Plus post, Torvalds noted that after Linux 4.8 kernel, we're now half-way between Linux 4.0. and 5.0. For those who don't know, Linux 3.20 turned into Linux 4.0.

It should be noted that Linux 3.9 and Linux 4.0 were released around 2 and 4 million Git object marks, respectively.

Source:

<https://fossbytes.com/linus-torvalds-linux-kernel-5-0-will-released-hit-6-million-git-objects/>

UBUNTU 16.10 LAUNCHES WITH A PREVIEW OF CANONICAL'S CONVERGED DESKTOP

Ubuntu 16.10 Yakkety Yak is ready for download. The

latest version includes a glimpse of the future: there's a preview of the Unity 8 desktop environment.

What makes Unity 8 interesting is that it's basically the same user interface that's already available for phones that run Ubuntu software. That means you'll have the same experience and be able to use the same apps whether you're using an Ubuntu phone, tablet, or desktop computer.

Unity 8 is still only available as a technical preview, so you can check it out if you want. But by default, Ubuntu 16.10 will load the latest version of the Unity 7 desktop environment.

If you do decide to switch to Unity 8, you get a user interface that doesn't look all that different, but which has been optimized for touchscreen displays. You also get support for "Scopes" which allow you to bring music, videos or other content into a floating window that's the equivalent of a full-page smartphone screen.

Other new features in Ubuntu 16.10 include a move to the Linux kernel 4.8, a newer version of the Nautilus file manager (if you're

using Unity 7), and newer builds of LibreOffice, Firefox, and other core software.

Source:

<http://liliputing.com/2016/10/ubuntu-16-10-launches-preview-canonicals-converged-desktop.html>

PARSIX GNU/LINUX 8.10 "ERIK" RECEIVES LATEST SECURITY UPDATES FROM DEBIAN STABLE

Parsix GNU/Linux 8.10 "Erik" is currently the latest stable and most advanced version of the distro, which launched officially on the last day of July 2016, based on Debian GNU/Linux 8 "Jessie," which means that its software repositories are always in sync with upstream to keep the OS secure and reliable until it reaches end of life.

You'll have to update your Parsix GNU/Linux 8.10 "Erik" installation, as it has received security updates for multiple core components and applications, including PHP5, NSS, NSPR,

IceDove, libav, Chromium, Wordpress, libdbd-mysql-perl, Jackrabbit, BIND9, and c-ares.

Also updated are the kernel packages, which are now based on the recently released Linux 4.4.24 LTS kernel. Therefore, we strongly recommend that you update your Parsix GNU/Linux 8.10 "Erik" system(s) as soon as possible to receive the security updates mentioned above and keep your installation healthy and secure.

Source:

<http://news.softpedia.com/news/parsix-gnu-linux-8-10-erik-receives-latest-security-updates-from-debian-stable-509275.shtml>

METASPLOIT EYEING LINUX AND USABILITY IMPROVEMENTS; IOS SUPPORT UNCERTAIN

Engineers at Rapid7, which owns the popular Metasploit penetration testing tool, are preparing a variety of enhancements for the ramp-up to version 5.0 in 2017.

Metasploit evolved in 2003, Rapid7 acquired it from the original developers in 2009, and fourth-generation software debuted in 2011. Metasploit Pro is currently in version 4.2 and costs several thousand dollars for a license; Metasploit Framework currently in version 4.12.33 is open source, officials explained.

Leo Varela, director of engineering, said his team is developing capabilities such as a single-pane interface, ways to convert Android vulnerabilities into corporate network access, a new focus on automated testing of network security controls, and a code base that's slimmer and faster.

Metasploit is traditionally Windows-centric. However, for Apple iOS testing, Boston-based Rapid7 is in the same boat as everyone else in the security and forensics fields—it's very difficult to do. Varela said he's open to adding iOS modules if the community of open-source Metasploit Framework users can help. Apple's mobile operating system is a custom version based on a derivative of Unix, and in recent and upcoming changes, "We

are adding the capabilities to be able to interact with Linux and with Unix," Varela noted.

Source:

<http://www.techrepublic.com/article/metasploit-eyeing-linux-and-usability-improvements-ios-support-uncertain/>

UBUNTU BUDGIE REMIX 16.10 OFFICIALLY RELEASED, AVAILABLE FOR DOWNLOAD NOW

Based on the recently released Ubuntu 16.10 (Yakkety Yak) distro, Ubuntu Budgie Remix (budgie-remix) 16.10 ships with a kernel from the Linux 4.8 series and it's built around the Budgie 10.2.7 desktop environment developed by the Solus Project. There are a lot of great new features implemented in this major version, such as full disk encryption support, Home folder encryption, and support for more languages during installation.

Taking a look at the software collection shipping with Ubuntu Budgie Remix (budgie-remix)

16.10, we can't help but notice that there are a dozen of apps from the GNOME 3.22 Stack, including GNOME Maps, GNOME Weather, Geary, and Rhythmbox, the latest version of the popular LibreOffice office suite, and the in-house built Budgie Welcome utility that promises to help newcomers quickly set up their new installations.

Source:

<http://news.softpedia.com/news/ubuntu-budgie-remix-16-10-officially-released-available-for-download-now-exclusive-509330.shtml>

PARROT SECURITY 3.2 "CYBERSLOOP" ETHICAL HACKING OS WITH LINUX KERNEL 4.7 RELEASED

If you are a hacker, pentester, or a security researcher, this news should interest you. The best Linux OS after Kali, Parrot Security 3.2 "CyberSloop" was released today. The developers released the second point release to the Debian-based Parrot Security 3.x GNU/Linux distribution designed

for ethical hackers and security researchers.

Surprisingly, the Parrot Security team has still not announced it as of yet but a vigilant reporter from Softpedia noticed the hacking OS go live on Parrot Security 3.2 "CyberSloop" going live on their website and decided to try it out. Dubbed CyberSloop and based on the Debian GNU/Linux 9 "Stretch (Debian Testing) operating system, Parrot Security 3.2 is now powered by Linux kernel 4.7.5.

Dubbed CyberSloop and based on the Debian GNU/Linux 9 "Stretch (Debian Testing) operating system, Parrot Security 3.2 is now powered by Linux kernel 4.7.5. The new OS has the latest MATE 1.16 desktop environment which would excite many hackers.

Source:

<http://www.techworm.net/2016/10/parrot-security-3-2-cybersloop-ethical-hacking-os-linux-kernel-4-7-released.html>

LINUX FOUNDATION WHACKS OPEN JAVASCRIPT PROJECTS UMBRELLA

A project fostering JavaScript's panoply of projects has been established by the Linux Foundation.

The JS Foundation will cultivate JavaScript application and server-side projects. The thinking is to create a centre that drives broad adoption and development of JavaScript technologies and that fosters collaboration. It should help devs and tools builders make sense of the rapid pace of change.

The focus on standardization and mentoring, JS Foundation executive director Kris Borchers told the Open Source Business Conference in London on Monday. The Linux Foundation and Node.JS will, in particular, work to advance the JavaScript language through bodies such as ECMA TC39 and the W3C.

Also, there'll be mentoring of projects around core principles of JavaScript.

Borchers told OSCON the

object is to build a center of gravity around JavaScript by bringing together projects.

Initial projects include Appium, Interledger.js, JerryScript, Mocha, Momentum.js. Node-Red and webpack.

Source:

http://www.theregister.co.uk/2016/10/17/js_foundation_from_linux_foundation/

CANONICAL BRINGS UBUNTU OPENSTACK, CEPH TO ARM SERVERS

Telco and enterprise customers are looking for an alternative source of silicon beyond Intel for their data center systems, according to Canonical officials.

ARM officials took a step forward in their effort to build the software ecosystem around its efforts in the data center when Canonical announced that its Ubuntu OpenStack and Ceph offerings are now commercially available on servers powered by ARM's 64-bit chip architecture.

Officials with both companies made the announcement Oct. 17, giving ARM more support in its strategy to become the primary alternative to Intel's x86-based processors in data center systems. Canonical officials said there is increasing demand from users of its open-source Ubuntu cloud and storage software for more options in the data center hardware they're running. The Ubuntu Linux operating system already runs on the ARM architecture.

Source:

<http://www.eweek.com/servers/canonical-brings-ubuntu-openstack-ceph-to-arm-servers.html>

NEW TOOL LETS YOU EASILY INSTALL THE UBUNTU TOUCH OS ON YOUR MOBILE DEVICES

Marius Quabeck from UbuntuFun.de informed about a new tool that lets users super easily install the Ubuntu Touch mobile operating system on their devices.

The tool is developed by Marius Quabeck himself and is called magic-device-tool. The first stable version, magic-device-tool 1.0, is now available to everyone and promises to offer a simple and easy-to-use batch tool for installing Canonical's Ubuntu Touch mobile OS, as well as Android, Cyanogenmod, or Phoenix OS.

In other words, you'll be able to replace your mobile operating system on your device with any of the following: the latest Ubuntu Touch release, Cyanogenmod - with or without the GAPPS (Google Apps) package, the factory Android image, as well as Phoenix OS. Please note that you'll only be able to run one of these OSes on your mobile devices.

magic-device-tool is also good for creating backups, restoring your device, locking or unlocking the bootloader, and installing TWRP recovery. To use it right now, you must use the commands listed below to fetch the latest Git build and run the tool, which only works under Ubuntu 16.04 LTS (Xenial Xerus) or Ubuntu 16.10 (Yakkety Yak) operating systems.

Source:

<http://news.softpedia.com/news/new-tool-lets-you-easily-install-ubuntu-touch-os-on-your-devices-with-dual-boot-509386.shtml>

VIRTUALBOX 5.1.8 OUT NOW, ORACLE ADDS LINUX KERNEL 4.8 SUPPORT IN VIRTUALBOX 5.0

The VirtualBox 5.1.8 point release is the most advanced Oracle VM VirtualBox version you can get right now, and it promises a month's worth of bug fixes and improvements to further stabilize the application for all supported platforms, including GNU/Linux, Mac OS X, and Microsoft Windows.

There are numerous changes implemented in VirtualBox, and among the most interesting ones we can mention support for using Audio Queues on Mac OS X hosts, the ability to parse port-forwarding rules that contain slashes, better keyboard handling for Windows and Mac OS X hosts, as well as improved support for deleting snapshots.

Linux kernel 4.7 and 4.8 improvements land in VirtualBox 5.0.28

While VirtualBox 5.1.8 also fixes the initialization of SAS controllers and adds Python 3 build support, Oracle brought improved support for the Linux 4.8 and 4.7 kernels to the long-term supported VirtualBox 5.0 branch with the VirtualBox 5.0.28 maintenance update, also released today and available for download from the project's website.

Source:

<http://news.softpedia.com/news/virtualbox-5-1-8-out-now-oracle-adds-linux-kernel-4-8-support-in-virtualbox-5-0-509433.shtml>

SOLUS 1.2.1 LINUX DISTRO RELEASED, ARRIVES WITH MATE EDITION FOR THE FIRST TIME

Solus 1.2.1 is the last fixed point released offered by the Solus Project. Other than the default Budgie Desktop, the Linux distro also comes with MATE 1.16 desktop. In the MATE edition,

improvements have been made to the Software Center which allows installation via a third party repository. The Linux kernel has been updated to 4.8.2.

The Solus Project has announced a point release of its Linux distribution in the name of Solus 1.2.1 Shannon. The new release is very important to Solus Project as it is the last Solus version to be delivered as a fixed point release. After Solus 1.2.1, the Solus Project is adopting the rolling release model for its Linux Distro.

Solus has its default graphical desktop called Budgie. But with the Solus 1.2.1, the Linux distro also comes in a MATE flavor other than the regular one. Solus Project considered MATE (v1.16.0) to be a good choice as it has a soft corner for the hardware-deprived machines.

Source:

<https://fossbytes.com/solus-1-2-1-mate-edition-released-features-download/>

CLEAR LINUX NOW POWERED BY KERNEL 4.8.1, ADDS WAYLAND 1.12, GNOME 3.22 & VIM 8.0

Clear Linux Project's Eva P. Hutanu informs the community about the latest updated components and new features implemented in the Clear Linux operating system during the past few weeks.

Key updated components added to the Clear Linux distribution include the Linux 4.8.1 kernel, systemd 231 init system, Vim 8.0 and Emacs 25.1 text editors, as well as node.js 6.8 server-side JavaScript environment. Many GNOME components are now based on the latest GNOME 3.22 Stack, and the recently released Wayland 1.12 display server is present.

Apache Maven open-source build manager for Java projects is also now available in Clear Linux, and it looks like key Python libraries, such as SciPy, NumPy, and scikit-learn received a bunch of performance improvements for Intel AVX2 (Advanced Vector

Extensions 2) processors.

Source:

<http://news.softpedia.com/news/central-linux-now-powered-by-kernel-4-8-1-adds-wayland-1-12-gnome-3-22-vim-8-0-509470.shtml>

LINUX USERS URGED TO PROTECT AGAINST 'DIRTY COW' SECURITY FLAW

Organisations and individuals have been urged to patch Linux servers immediately or risk falling victim to exploits for a Linux kernel security flaw dubbed 'Dirty COW'. This follows a warning from open source software vendor Red Hat that the flaw is being exploited in the wild. Phil Oester, the Linux security researcher who uncovered the flaw, explained to V3 that the exploit is easy to execute and will almost certainly become more widely used. "The exploit in the wild is trivial to execute, never fails and has probably been around for years - the version I obtained was compiled with gcc 4.8," he said. "As Linus [Torvalds] notes in his commit, this is an ancient bug and impacts kernels going back many

years. All Linux users need to take this bug very seriously, and patch their systems ASAP." Oester said that he uncovered the exploit for the bug, which has been around since 2007, while examining a server that appeared to have been attacked.

Source:

<http://www.v3.co.uk/v3-uk/news/2474845/linux-users-urged-to-protect-against-dirty-cow-security-flaw>



The Ubuntu Podcast covers all the latest news and issues facing Ubuntu Linux users and Free Software fans in general. The show appeals to the newest user and the oldest coder. Our discussions cover the development of Ubuntu but aren't overly technical. We are lucky enough to have some great guests on the show, telling us first hand about the latest exciting developments they are working on, in a way that we can all understand! We also talk about the Ubuntu community and what it gets up to.

The show is presented by members of the UK's Ubuntu Linux community. Because it is covered by the Ubuntu Code of Conduct it is suitable for all.

The show is broadcast live every fortnight on a Tuesday evening (British time) and is available for download the following day.

podcast.ubuntu-uk.org



Over the last few months, I've written a few articles that I promised to follow-up on, and also received some emails from readers whose information I should pass along:

PRINT SERVER

To recap: I wanted to set up a Raspberry Pi 3 for use as a print server (with google cloud print via chromium) for usage with a Brother MFC-230c printer. I set up as much of the software as possible before leaving, but at the point where I wrote the article, had not yet tested it.

The update: The raspberry pi (RPi) settings (for wireless) worked out of the box, meaning I was able to just plug in the power adapter, and then direct myself to the IP of the device that I had pre-programmed statically. After that, I made sure the CUPS server was available (which was fine), and double-checked the chromium install. So far, so good.

Problem #1: Brother doesn't offer ARM-based drivers for the 230C, and therefore I couldn't actually install the printer on the RPi for use with chromium and google cloud print. However, I did connect the printer in RAW mode, where the RPi acted basically as a network interface for the printer, allowing network printing on all devices that could install drivers for the printer locally. Basically how network printers work these days.

Problem #2: However, one of the devices was a Chromebook, for which drivers could not be installed (as it runs through Google Cloud Print). What I did here was set up the printer on my laptop, and then added it to google cloud print, and then shared it to the Chromebook. This worked fine, so long as my laptop was on and Chrome was open. Seeing as USB printing wouldn't have worked from the Chromebook anyway, it was the only solution left, and wasn't too annoying to use.

What I learned: Check for ARM

drivers before assuming a RPi can work as a print server like that, or else just use the RAW mode in CUPS.

MUSIC ENGRAVING

To recap: I wrote an article on using LilyPond to write guitar tablature (and musical notation). At the time, LilyPond was the only example of a LaTeX-like engraving system I knew of.

The update: A reader emailed me after the article was published, and suggested I look at MUP. I have since done so, and tried to recreate a couple of the tabs from LilyPond.

The good: I do find the syntax to be a little more readable than LilyPond's, and some of the defaults seem a little more sane.

The bad: The documentation. Just googling for MUP generally brings up results for meteor-up, and when you can find MUP (by arkkra), they seem to have only a user guide (which to me, is more of a thorough manual than a guide).

However, LilyPond offers a wide variety of examples (and user-created content), which I have simply not been able to find to the same degree with MUP.

The result: I have written a few MUP files, and can generate PDF and PS files. However, it took me some time to figure out how to actually have MUP produce tablature. It also has issues with some characters (such as umlaute), and the documentation for creating your own font files is sorely lacking.

Resource:
<http://www.arkkra.com/doc/uguide/index.html>

My request: If anyone has more experience with MUP (or knows of a good resource), please send me an email (my email address is in the conclusion).

If you have any experience with LilyPond or MUP - let me know! As always, you can reach me at lswest34+fc@gmail.com.



HOW-TO

Written by Greg D. Walters

Python In The Real World - Pt 71

This month, we are going to interface a servo motor to our RPi. This requires only a servo motor, the Raspberry Pi, the breadboard, some jumpers, and the battery pack we used last month.

A servo motor is simply a motor that has a control circuit and a potentiometer to give the control circuit the position of the output shaft. MOST servos will rotate the shaft between 0° and 180°. There are some that go 360° and more, but they cost a lot. Gears do all the connections between the motor, the potentiometer, and the output shaft. We provide the power through batteries or another external power source, and the RPi will send out the control signals. Most servos have only three wires, Positive voltage, Negative voltage (ground) and Control Signal. Colors of the wires vary from manufacture to manufacture, but the voltage wires should be close in colour to red and black, and the control wire is the only one left. When in doubt, check for a data sheet from the manufacture.

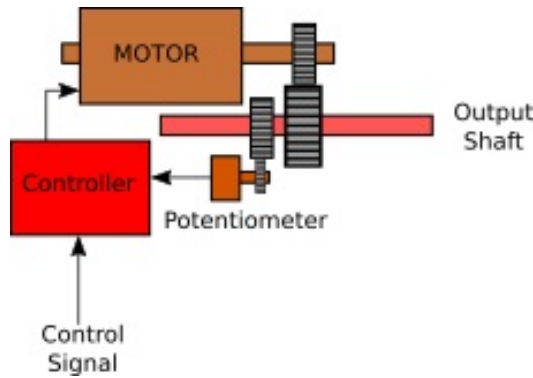

The control signals are expected in a very specific "format", and we will use PWM (Pulse Width Modulation) for that. First, the pulses must come every 20 milliseconds. The width of the pulse determines where the output shaft turns to. If the pulse is 1 ms in width, the motor will move toward 0°. If the pulse is 1.5 ms, then the shaft moves toward 90°. If the pulse is 2 ms, the shaft moves toward 180°

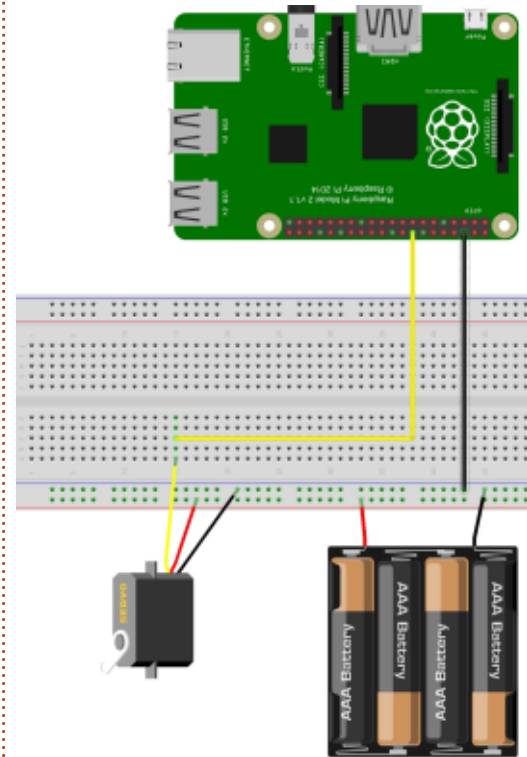
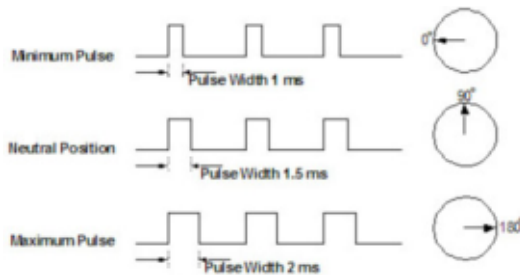

THE WIRING

The connections are very simple this month. The battery pack powers the motor, so +voltage on the servo goes to the + voltage rail, and the negative servo wire goes to the negative rail. We connect the negative voltage from the battery pack (negative rail) to pin 6 of the RPi. GPIO pin 23 (pin 16) goes to the control wire of the

servo.

Now for some math. As we discussed earlier, the servo expects a signal every 20 ms in order to work, and we need to keep sending those pulses to keep the output shaft in the position that we want it in. The GPIO command to set the Pulse Width Modulation is

```
Pwm = GPIO.pwm({Rpi Pin},{Frequency})
```

We know the pin number (23), but we need to convert the 20 ms to Hertz in order to set the pwm setup command. How do we do that? It's simple.

```
Frequency = 1/time
Frequency = 1/.02 (20ms)
Frequency = 50 Hertz
```

So now, when we set up our code, we can set the GPIO.pwm command to the control pin and use 50 for our frequency.

Our first program will start somewhere close to 0° and then move to close to 90° then move to

close to 180°. I keep saying close, because every servo is a bit different. We don't want to set the DutyCycle to 0 and have it slam to the limit and potentially damage the servo, so we will start off with a low number close to 0 and end with a number close to 12 in order to start to "dial in" a set of values that work. For my servo, the numbers 3 for 0° and 12 for 180° worked well.

SERVO1.PY

```
import RPi.GPIO as GPIO
from time import sleep

GPIO.setmode(GPIO.BCM)
GPIO.setup(23, GPIO.OUT)

pwm = GPIO.PWM(23, 50)
pwm.start(2)
pwm.ChangeDutyCycle(3)
sleep(5)
```

3 should give you the first angle. You might need to try changing it to 2, 1, 0 or 4 to get it there. Write down this number.

```
pwm.ChangeDutyCycle(6)

sleep(5)
```

This should put the rotor into the centre position (90°). If you have changed the first number or the next number, this will have to

change as well.

```
pwm.ChangeDutyCycle(12)

sleep(5)
```

The final number should take you to the 180° position. Again, try a few numbers one side or the other to tweak this, and once you have it, write down the number.

```
GPIO.cleanup()
```

Finally we call GPIO.cleanup() to set everything to normal.

Now comes the heavy duty math part. We will use the values 3 and 12 as y1 and y2 respectively for the formula. Substitute your numbers.

```
Offset = (y2-y1)/(x2-x1)
Offset = (12-3)/(180-0)
Offset = 9/180
Offset = .05
```

Now when we set the DutyCycle based on an angle between 0° and 180° we use the following formula

```
DutyCycle = (Offset * angle) + 2.0

DutyCycle = (.05 * angle) + 2.0
```

Servo2.py

```
import RPi.GPIO as GPIO
from time import sleep
GPIO.setmode(GPIO.BCM)
GPIO.setup(23, GPIO.OUT)
pwm = GPIO.PWM(23, 50)
pwm.start(2)
def SetAngle(angle):
    DutyCycle=(.061 * angle) + 2.0
    print(DutyCycle, angle)
    pwm.ChangeDutyCycle(DutyCycle)

try:
    while True:
        for a in range(0,180):
            SetAngle(a)
            sleep(.05)

        for a in range(180,0,-1):
            SetAngle(a)
            sleep(.05)

except KeyboardInterrupt:
    GPIO.cleanup()
```

When I did this, it worked, but I found the value of .061 worked a little bit better.

Well, that's about it for this month. Next time, we will be working with a stepper motor, somewhat a cross of both a servo and a regular motor.

Until then, enjoy!



Greg Walters is owner of RainyDay Solutions, LLC, a consulting company in Aurora, Colorado, and has been programming since 1972. He enjoys cooking, hiking, music, and spending time with his family.



By way of introduction, I should say that my PC doesn't encounter overheating problems for virtually all programs. However, I do quite a lot of video transcoding (altering an audio-video file from one format to another). It is highly CPU intensive, uses 100% of all CPU cores and runs for long periods. As a result, my CPU gets excessively hot. So I have a requirement to prevent this program from killing my CPU.

It is true that the CPU is continuously monitoring temperature and that, when a critical temperature is reached, it would take certain actions (for example, drastically reducing the clock speed in order to reduce the power consumption), until the temperature falls to a sub-critical value. This is all very well as it prevents an actual meltdown event, but running components at high temperatures on a continuous basis will seriously shorten their life.

I use an excellent GUI program called HandBrake for my

```
jeremy@HAL:~$ inxi
CPU~Dual core Intel Core i3-3110M (-HT-MCP-) speed/max~1239/2400 MHz Kernel~4.4.0-34-generic x86_64 Up~1:05 Mem~777.2/3733.0MB HDD~500.1GB(1.8% used) Procs~214 Client~Shell inxi~2.2.35
```

transcoding – a Command Line version is also available. Because this is not a time-critical application (for me), I want to, somehow, suspend/resume it based on the temperature of the CPU. The motherboard and CPU contain a number of sensors of various kinds, which provide information to the Linux Kernel. However, this is of no help to me as I just need a simple, standard way to monitor the temperature.

So my programme is:-

- Get the CPU temperature.
- Find out how to suspend multiple processes.
- Find out how to resume these multiple processes.
- Write a simple script to maintain the CPU at an acceptable temperature.

It turns out that the first step is the most interesting. A set of scripts has been maintained for a number of years for most distros

to access hardware related information. By default, the latest Ubuntu (16.04) doesn't include the inxi package from the Universe repository (Community-maintained free and open-source software). You may need to select this repository – if it is not already selected. To install inxi, possibly with a few dependencies:

```
sudo apt install inxi
```

We don't need any special authorities to run the inxi command in a Terminal window; it has a very large number of possible options. For example, inxi with no options gives the result shown in the image at the top of this page.

Which looks promising, however when coloured characters are shown on the terminal, this is done by transmitting non-text characters to the screen – in a text editor this looks like:-

```
#[1;34mCPU#[0;37m~Dual core Intel Core i3-3110M (-HT-MCP-)#[1;34mspeed/max#[0;37m~1239/2400 MHz....
```

Where the # represents some non-printable character.

A good way of preparing a short description of your computer to send elsewhere would be to run:

```
inxi -c0 > summary-file (the -c0 option specifies text-only output).
```

and then email that summary-file.

The summary-file looks like

```
CPU~Quad core AMD FX-4350 (-MCP-) clocked at 1400 Mhz Kernel~3.16.0-4-amd64 x86_64 Up~8:08 Mem~1564.9/7905.2MB HDD~2000.4GB(37.0% used) Procs~196 Client~Shell inxi~2.1.28
```

Two points:

- You may notice I've switched to a different machine (for

HOWTO - STOP YOUR CPU OVERHEATING

convenience) and that the output is now an ordinary text file, although it is not quite as easy to read as the coloured, formatted version.

- I won't go through all the options, since the full documentation can be viewed with the `man inxi` command.

We shall be mainly interested in the `inxi -s` command, as this shows the state of the sensors. This should work on all laptops, but might require some work on some older desktops. If `inxi -s` does not show any CPU temperature, then consider running the procedures detailed in

<https://help.ubuntu.com/community/SensorInstallHowto>

My `inxi -s` looks like this, but the amount of information you get will depend on your PC.

I won't worry about the presence of those non-text characters as I just want to pick up the first two digits of the first number on the first line. For us this is a fixed layout. We can therefore bolt a couple of standard programs

```
jeremy@hector ~ $ inxi -s
Sensors: System Temperatures: cpu: 33.0C mobo: 27.0C gpu: 35C
Fan Speeds (in rpm): cpu: 2376 fan-2: 1231 fan-3: 0
```

together:

```
inxi -s | grep 'System
Temperatures' | cut -b 66-67
```

The `grep` statement outputs all lines that have 'System Temperatures' in them (just the first line). This line is then piped into a `cut` command where we specify that we just want bytes 66 & 67 of the line. So running the above command should output 33. Note that other tools, such as 'sed', could do the same job, only with more flexibility.

Moving on to the problem of suspending/resuming active processes, it turns out to be ridiculously easy! If we were to issue a "normal" `killall 'program name'` command, then all matching processes are sent a `TERM` signal, causing the processes to terminate themselves. However, we can send less destructive signals.

`killall -s STOP 'program name'` will cause all the relevant processes to pause themselves.

`killall -s CONT 'program name'` will cause all the relevant

processes to resume themselves.

I've written a short monitoring script (called `schedule.sh`) which can be run from a Terminal window. It contains an infinite loop, so that when it is no longer wanted it has to be terminated by `CTRL+C`. Normally, I use it for `HandBrake`, which runs a program called 'ghb', but it could be used for any CPU-greedy program. So `./schedule.sh 'program name'` should work for any program.

In choosing the hard-coded values for temperature, 59°C was really as hot as I wanted to go, but 45°C was chosen as a lower limit because the rate of cooling is proportional to the difference between the temperature of the hot object and the temperature of its surroundings. So there isn't any point in aiming for anything much lower. The range of 45° - 59° still gives a few minutes run-time between pauses, especially as the usual cooling methods are continuously removing some of the heat during the run phase.

If I run any other programs

```
jeremy@hector ~ $ inxi -Gxx
Graphics: Card: NVIDIA GK208 [GeForce GT 730] bus-ID: 01:00.0 chip-ID: 10de:1287
Display Server: X.Org 1.16.4 driver: nvidia Resolution: 1920x1080@60.00hz
GLX Renderer: GeForce GT 730/PCIe/SSE2
GLX Version: 4.4.0 NVIDIA 340.96 Direct Rendering: Yes
```

concurrently, then they are unaffected; any excessive CPU usage would simply cause the monitored program to get suspended slightly more often. I don't claim that this is anything other than a sticking plaster solution to my problem. However, I've discovered useful new features of `inxi` and `killall`.

I've included a Bash script for `schedule.sh` which may not be beautiful, but it works. It can also be found at

<http://pastebin.com/yiDfJ4iF>

So, to run my heavyweight transcoding program, protected against high temperatures:-

- Run `./schedule.sh` in a Terminal Window and leave it running
- Run `Handbrake` in a GUI Window
- Go and do something else.

As an example of what `inxi` is capable of, I'll round off with a quick way of obtaining a display of some quite detailed information about my graphics card, using the `-G` parameter and adding a 'xx' parameter asks for extra, extra details.



In this series of articles, I will be building a text-based application with Free Pascal, using its text-based interface for user interaction. This will be combined with other, more modern, technologies such as database access using SQL and Web access with HTTP. The final aim of the project is to demonstrate how Pascal can be used to build a modern application, while avoiding the overhead associated with a graphical interface that uses a widget set such as GTK or Qt.

In the previous part of the series, we covered setting up a small SQLite database, then building a command-line Free Pascal program to access it. Finally, we integrated the database code into our Free Vision application through a new Dialog type to connect to the database and display data retrieved. In this fourth part of the series, we will connect to the Internet in order to refresh the information in our database directly from the Full Circle Magazine website.

TOOLS TO CONNECT TO THE NETWORK

The default installation of Free Pascal does not always come with the network units; if we installed the compiler using the apt method under Ubuntu, we will need to install a supplementary package:

```
apt install fp-units-net
```

This will make several units available to us, both for simple HTTP connections and for more complex scenarios such as OpenSSL. In our case, we will merely be connecting to the Internet to pull down the RSS feed for our favorite magazine. For this task, we can follow one of several different strategies. One would be to build our own HTTP protocol client, starting from bare sockets. This would certainly be feasible and not very complex for a simple connection, given the simple nature of the HTTP protocol. However, things can get a tad more complex when HTTPS connections are required - as, indeed, they are nowadays for many services such

as Google. Besides, parsing HTTP code quickly gets tedious. This is where a second strategy comes in, which is to use an existing library to encapsulate these tasks. The application programmer can then concentrate on the actual data being transferred, leaving low-level connection mechanisms to the library.

The well-known library libcurl is standard in many POSIX environments, and the Free Pascal project has made it available through an appropriate unit. The CURL or "C-URL" (pronounced "see URL") library is, no doubt, a bit of an overkill for our task, but it is very easy to set up and use. The interested reader can peruse the documentation at the project's site (<https://curl.haxx.se/>) to find out more. A short extract from the website will help understand what it is capable of doing:

"A free and easy-to-use client-side URL transfer library, supporting DICT, FILE, FTP, FTPS, GOPHER, HTTP, HTTPS, IMAP, IMAPS, LDAP, LDAPS, POP3, POP3S, RTMP, RTSP,

SCP, SFTP, SMB, SMBS, SMTP, SMTPS, TELNET and TFTP. libcurl supports HTTPS certificates, HTTP POST, HTTP PUT, FTP uploading, Kerberos, SPNEGO, HTTP form based upload, proxies, cookies, user+password authentication, file transfer resume, http proxy tunneling, and more!"

However, most Ubuntu installations contain the libcurl library itself, but not the header files. In order to use it in conjunction with a compiled language such as Free Pascal, we will need to install the corresponding header files as well. The actual version may change across distro versions, but in Ubuntu 16.04 and Linux Mint 18 the following command should set you up:

```
apt install libcurl4-gnutls-dev
```

As a final note, it must be said that CURL is fast - usually much faster than opening a web page in a browser. This fits in well with Free Pascal's general lightweight and fast operation.

WHAT SHALL WE BE DOWNLOADING FROM THE WEB?

What we are basically looking for is a list of recent publications of Full Circle Magazine. This is quite a simple task for a human reader: simply navigate to the web page, and read the articles choosing those with “Full Circle Magazine” in the title (as opposed to “Weekly News”) or something else. However, it is more difficult for a computer program than for a human to do this, since it must somehow learn to distinguish between articles and background elements, images, etc. Modern web pages are in fact quite complex assemblies of information. So let us help our program by using the facilities built into a modern Content Management System (CMS) such as Wordpress used by FCM. One of these is the Rich Site Summary (RSS) feed.

An RSS feed is a way of querying the site’s database of articles. Most CMS allow us to build a query along several different lines. In the case of FCM,

we can use the following query to get a list of all articles:

<http://fullcirclemagazine.org/feed/>

If we open it in our web browser, we will get a properly formatted page since modern browsers are aware of the underlying code in eXtended Meta Language (XML), and can parse it correctly. However, we should be aware that what has really come across the network looks like that shown in the image below.

If anybody is interested, I actually obtained the accompanying screenshot using the CURL command by itself:

```
$ curl
http://fullcirclemagazine.org/feed/ | less
```

Other queries can be handled in a similar fashion. For example, to locate all articles that are tagged with “podcast”, “python”, “pascal” etc.:

```
http://fullcirclemagazine.org/tag/podcast/feed/
```

```
<channel>
  <title>Full Circle Magazine</title>
  <atom:link href="http://fullcirclemagazine.org/feed/" rel="self" type="application/rss+xml" />
  <link>http://fullcirclemagazine.org</link>
  <description>The independent magazine for the Ubuntu Linux community.</description>
  <lastBuildDate>Sat, 16 Jul 2016 19:30:06 +0000</lastBuildDate>
  <language>en-US</language>
  <sy:updatePeriod>hourly</sy:updatePeriod>
```

```
http://fullcirclemagazine.org/tag/python/feed/
```

```
http://fullcirclemagazine.org/tag/pascal/feed/
```

Ronnie has actually included a simplified version of the feed for the Weekly News podcast:

```
http://fullcirclemagazine.org/feed/podcast
```

This mechanism can be used to specify articles published by a specific author. Since articles announcing a new issue of FCM are invariably by Ronnie, we can use this URL to filter them out:

```
http://fullcirclemagazine.org/author/ronnie-2/feed/
```

This is what we will be using to help our search for new issues.

COMBINING THE PIECES

So far, we have a means of connecting to the Web, and downloading a single page, from

its URL. On the other hand, we have a specific URL that allows us to get dynamic content built from the FCM content management system. Let us put this together in a 20-line Pascal program (with empty lines and nice formatting). First, we need to include the unit, and declare a couple of variables:

```
uses
  LibCurl;

Var
  URL : PChar =
    'http://fullcirclemagazine.org/author/ronnie-2/feed/';

  hCurl : pCurl;
```

The first variable is simply the URL we will be passing on to libcurl, though in PChar format. Pascal strings were from its origin arrays of 256 bytes. Bytes in positions 1 to 255 held the ASCII codes for each character, while position 0 held the total number of characters in the string. Needless to say, this scheme has several limitations, including the handling

of strings with more than 255 characters and using multiple-byte codifications (think Unicode). On the other hand, the C programming language - in which most of the Internet has been developed - traditionally uses null-terminated strings. These are simply an area of contiguous memory long enough to hold the string, and a special null character at its end. Luckily, these can also easily be used in Pascal through the Pchar type, which is simply a pointer to a character.

The second variable is a pointer to the CURL routine that will handle our connection. The following code has been directly copied from the unit's example:

```
hCurl:= curl_easy_init;  
if Assigned(hCurl) then  
begin
```

```
curl_easy_setopt(hCurl, CURLOPT_VERBOSE, [True]);
```

```
curl_easy_setopt(hCurl, CURLOPT_URL, [URL]);
```

```
curl_easy_perform(hCurl);  
curl_easy_cleanup(hCurl);  
end;
```

A handler process is set up with `curl_easy_init`. If this worked (we have access to the dynamic library

and enough free memory), we can then set a pair of options (verbose output on screen, the URL we wish to parse). `curl_easy_perform` does the actual work of downloading the page, and finally `curl_easy_cleanup` free up any memory used.

The complete code of this program is available here: <http://pastebin.com/QM9m3jug>

If we compile and run the above program, we simply get the XML code returned by the FCM server echoed on screen. To do something useful with this data, we could for example write it to a file. To be more precise, we will need to get the CURL handler to do this for us. The process will take place in two steps.

In the first step, we will pass the handler a callback function to transform its internal data structure into a byte stream. This function needs to be declared with a very precise syntax, since it will in fact be called by the main CURL handler - which has been written in C. This is, in fact, a good example of using multiple programming languages within the same compiled object.

```
Function DoWrite(Ptr :  
Pointer; Size : size_t;  
nmemb: size_t; Data :  
Pointer) : size_t; cdecl;
```

```
begin  
DoWrite :=  
TStream(Data).Write(Ptr^, Size  
*nmemb);  
end;
```

In the second step, we will create a new file stream and instruct the handler to use the `DoWrite` function to populate it. So, begin by creating an appropriate `TFileStream`, and open it:

```
Var  
f : TFileStream;
```

```
begin
```

```
f:=TFileStream.Create('fcm.xml',fmCreate);
```

Continue by setting up `hCurl` options as before, but add:

```
curl_easy_setopt(hCurl, CURLOPT_WRITEFUNCTION, [@DoWrite]);
```

```
curl_easy_setopt(hCurl, CURLOPT_WRITEDATA, [Pointer(f)]);
```

The `curl_easy_perform` and `curl_easy_cleanup` stages take place as before. Do not forget to close the file stream at the end of the program:

```
f.Free;
```

The complete code for this program is available at this link: <http://pastebin.com/Ayth2cfK>

In this part of our series on Free Pascal, we deviated a bit from Free Vision and went into the technical details on how to use the CURL library from Pascal to connect to an RSS feed on FCM's content management system. At this stage, we know how to connect to the server and download an XML file containing a list of recent articles published on the web page. In the next part of our series, we will see how to parse the XML code to retrieve the information we are aiming for: issue numbers and download URLs.



Alan holds a PhD in Information and the Knowledge Society. He teaches computer science at Escola Andorrana de Batxillerat (high-school). He has previously given GNU/Linux courses at the University of Andorra and taught GNU/Linux systems administration at the Open University of Catalunya (UOC).

UbuCon Europe 2016

18.-20. November 2016 | Unperfekthaus, Essen, Germany, Europe



ubucon.eu





HOW-TO

Written by Mark Crutch

Inkscape - Part 54

This month, we're going to look at the Convolve Matrix filter primitive. Convolution is a mathematical term for a process of repeatedly applying one function to the varying output of another function. In the computing world, it's commonly used with discrete values, rather than continuous ones, as you might get when dealing with sampled audio or, indeed, with individual pixels in an image. So, in digital signal processing, convolution generally means using a function to map a series of values to a new series. In SVG filter terms, that means mapping one set of pixels to a new set. The "function" is defined using a matrix of numbers, hence the filter name is "Convolve Matrix" - although "map pixel values using a matrix" would have perhaps made it a little more understandable to the layman.

Let's look at how a convolution matrix actually works by picturing its effect on a simple image made up of a small set of pixels. For this demonstration, we'll use black and white pixels with values of 0 and

255 (with numbers in-between being shades of gray). In a real filter there are three color channels, so our single-channel black-and-white image here is merely a model to represent the calculation process. The shape we'll use is just a 9-pixel square inside a larger 25-pixel square.

255	255	255	255	255
255	0	0	0	255
255	0	0	0	255
255	0	0	0	255
255	255	255	255	255

Our first matrix will be a 3x3 array, with each cell containing the number 1.00, and the "target" specified as the center cell of the matrix. Here's how that looks in the Inkscape GUI:

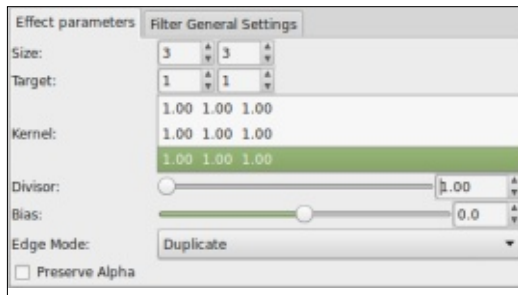

The convolution process itself consists of taking our matrix and positioning it so that the target cell in the matrix is positioned over each pixel in the input image, in turn. We're going to look at the calculation that takes place for the first black pixel in our input image - the one with the red outline. The 9 pixels covered by the matrix are all multiplied by the corresponding value in the matrix cell, then added together. The result is clamped so that it doesn't exceed 255 or drop below 0, and is then used as the value for the output pixel. This image might clarify things a little - the green area represents the 3x3 matrix, with each pixel's contribution to the output shown.

255	255	255	255	255
255	0	0	0	255
255	0	0	0	255
255	0	0	0	255
255	255	255	255	255

255	255	255	255	255
255	0	0	0	255
255	0	0	0	255
255	0	0	0	255
255	255	255	255	255

The value of the output pixel is therefore:

$$(255 \times 1.00) + (255 \times 1.00) + (255 \times 1.00) + (0 \times 1.00) + (0 \times 1.00) + (0 \times 1.00) + (0 \times 1.00) + (0 \times 1.00) + (0 \times 1.00)$$

It doesn't take much mathematical skill to realise that the five white pixels each contribute a value of 255 to the output, whilst the black pixels contribute nothing. So the value used as the output pixel is just $255 \times 5 = 1,275$. Except that the output values are clamped, so the actual output value is just 255 - this matrix has turned the black pixel into a white one.

255	255	255	255	255
255	0	0	0	255
255	0	0	0	255
255	0	0	0	255
255	255	255	255	255



Moving on to the next pixel, we get a similar result. This time there are only three white pixels that contribute to the output, but that's still a value of 765, which gets clamped, so the output is again white.

Considering the remaining black pixels in our test image, it's pretty obvious that all the outside ones will turn white. In fact it's only the very center pixel that remains black. So the output from this particular convolution matrix is just a single black pixel at the center of a white square.

Some of you may have noticed that I've conveniently started with a pixel that is not on the very edge of the filter area. How does Inkscape calculate the value for the top-left pixel, for example, given that five of the points covered by the matrix simply don't exist? The answer lies in the Edge Mode popup in the filter settings: "Duplicate" copies the pixels from the outer edge to fill any missing values; "Wrap" uses the pixels from the opposite side of the image to fill the gaps as though it were working on a tiled version of the input; "None" just sets the channel

values for the missing pixels to zero.

Or at least that's how it's supposed to work. According to the official Inkscape manual, this parameter is completely ignored by Inkscape, despite being present in the UI. It doesn't specify what method is used to calculate the missing pixels and, as the official manual has not been updated for version 0.91, I'm not sure if this situation has changed with the more recent release. So we'll just ignore the question, and assume that Inkscape does something to populate the missing pixels or omit them from the calculation, so that we don't have to worry too much about it.

Because the values we've chosen tend to result in calculations that get clamped, our filter, as it stands, pretty much just creates black and white pixels in the output. Before clamping, we were getting results of 1,275 and 765, but we then proceed to throw away any difference between the values because they're both greater than 255. By using the Divisor control in the filter settings, we're able to scale the output of the calculations prior to

any clamping, allowing us to rein in the values to preserve those differences. A good rule of thumb is to set the divisor to the same value as the total of the individual numbers in your matrix. By setting it to 9 in our example image, the outputs of 1,275 and 765 are reduced to 142 ($1,275 \div 9$) and 85 ($765 \div 9$), giving us this result:

255	255	255	255	255
255	142	85	142	255
255	85	0	85	255
255	142	85	142	255
255	255	255	255	255

Now each output pixel is the average of nine pixels from the input image. Although it might not be clear from this small example, the outcome is a simple blurring of the input image. In reality, it would be better to use a Gaussian Blur primitive if you just want to soften your image a bit, but this was, of course, just a demonstration of the mathematics that takes place behind the scenes with the

Convolve Matrix.

Now let's move on to some more interesting matrices. I'm going to stop with the pixel-by-pixel approach, and the mathematical explanations – it's all just an extension of the examples I've shown so far, but with larger images and multiple color channels. We'll use a different classical image to demonstrate these because Mona, quite honestly, isn't that interesting when you apply a convolution matrix. So we'll switch to Michelangelo's "Creation of Adam", with each image showing the unfiltered version at the top left, and the filtered one at the bottom right. We'll start with a "Sobel" matrix:

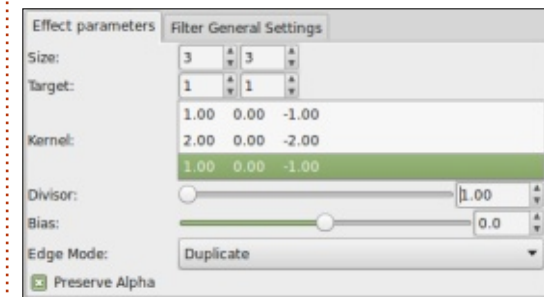

A Sobel operator emphasises the differences between adjacent pixels in one direction or another. The result is essentially a map with bright colors where there is a sharp

HOWTO - INKSCAPE

transition between pixels, and dark colors where there is little or no difference between adjacent pixels. In practical terms, therefore, it acts as an edge detection filter, in this case highlighting vertical edges (note, particularly, the coving at the right of the image).



Rotating the values of the matrix through 90° (so that the top row contains 1, 2, 1 and the bottom row is -1, -2, -1) turns it into an edge detection filter for horizontal edges. In this case the coving vanishes, but any near-horizontal shapes are accentuated:



A more general form of edge detection, which highlights both vertical and horizontal lines resulting in an “outline” version of the original image, can be achieved

with the following matrix:

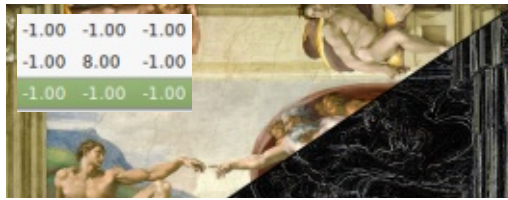

It's easy to imagine this, followed by a Color Matrix primitive, forming the basis of a “pencil sketch” filter chain, but you can achieve a similar result by using the Bias parameter in the filter preferences. This lets you add a fixed offset to the result of each calculation, and acts to brighten or darken the output image. Setting this parameter to 1.0 with the previous filter gives this result:



A variation on edge detection is edge enhancement. This matrix will emphasise edges but still allow the original colors to show through, resulting in a sharpened appearance to the image:

Here's another matrix that

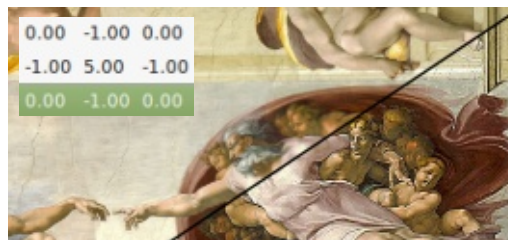

darkens some edges whilst lightening others, giving rise to an embossed appearance.

As you can see, there are a

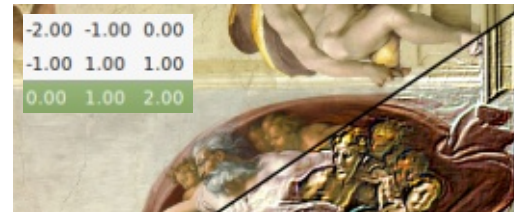

variety of effects that can be produced with this primitive, although it's far from intuitive to work out what values you need to enter into the matrix to get a particular output. Although the matrix approach allows for a vast number of possibilities, there are really only a few well-known matrices that are commonly used. A search online will provide you with some more examples, but they all fall into the same basic themes I've covered here.

Before concluding, there are a few more controls in the filter UI that need to be explained. The Size parameter, as you might expect, sets the size of the matrix. I've only used 3x3 matrices in this article, but 5x5 is also a common size, and you could go higher still, to consider a wider area around each source pixel. Just remember that the size of the matrix defines how

many pixels need to be read and calculated for each output pixel, so increasing this parameter can quickly impose a much larger processing burden on Inkscape.

In the examples here, I've assumed that the center of the matrix is positioned over the target pixel for each calculation. It's possible to change that using the Target fields in the UI, where 0,0 would set the top-left cell of the matrix as the target. All this does is shift the output a little, so there's little reason to worry about it too much.

Finally, the Preserve Alpha checkbox determines whether the alpha of the original pixel is transferred to the output unchanged (checked), or if the alpha channel is also subject to the convolution process (unchecked). I tend to leave this checked, as it's one less channel of calculations for Inkscape to perform, and I haven't yet found myself needing to convolve the alpha channel.

Image Credits

“The Creation of Adam” by Michelangelo
<https://en.wikipedia.org>



The most popular use for Google Drive is photo storage. I do not have access to an Ubuntu phone, so I use an iPhone. The iPhone is notorious for its 16GB of storage. I installed the Google Drive App onto my phone and enabled Google Photos to sync towards my photo albums. This allows my photos to be backed up online via Google Drive.

I have used my Drive for photo storage for close to 6 months, and I have yet to find a serious flaw.

I cannot edit the photos using GIMP since it is not on Chrome OS as of September 2016. So I poked around a bit in the Chrome Web Store and found a replacement app called Pixlr Editor. It does not invade your privacy, but it needs access to your Chromebook's SSD or Drive. The app has a side advertising panel, however my Ghostery Extension blocks the content. You are not required to have a login or to subscribe to the Pixlr Editor website. However a login enables using Pixlr Editor's cloud storage for your projects.

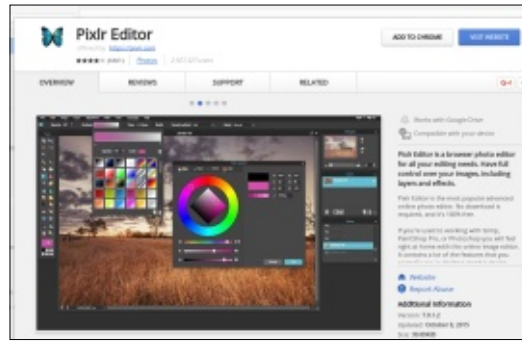

You can open a picture straight from the Pixlr Editor directly or indirectly through Google Photos via a Pixlr Editor shortcut on the Drive. The chosen picture would then appear in the Pixlr Editor app.

I choose a simple bumblebee picture from my Drive.

The app can be divided into two major areas: tools and picture pane. There are 3 sub-areas after the picture pane: navigator, layers, and history. The right of the screen is the advertising app. These 5 panes create the online photo editor.

The tools pane has the typical array seen in GIMP such as cropping, paint brushes, text

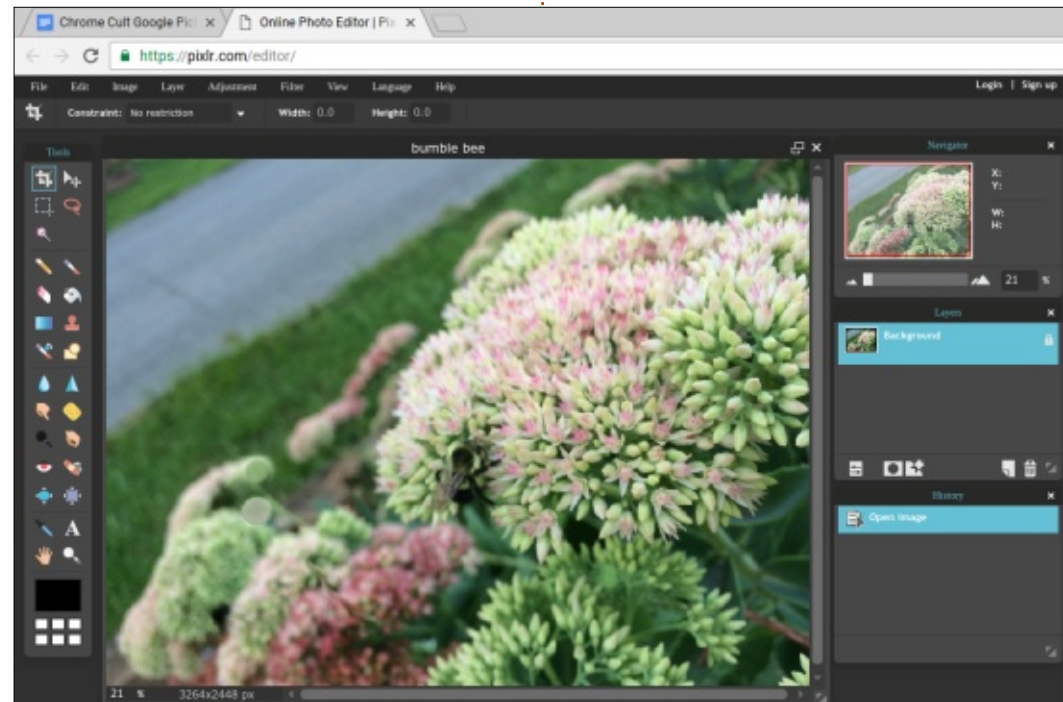

boxes, etc. The navigator is useful for focusing on certain areas of the picture. The layers show the various effects implemented by tools, and the history shows the order of layers performed.

When you are finished, you can save your work in a png, jpeg, bmp, tiff, or pxd format. And the finished picture can be saved directly to your Chromebook.

I successfully used Pixlr Editor for presentations. It does not have all of the bells and whistles as GIMP, yet it is a surprisingly effective online photo editor. This app will suffice for most hobby photographers.



SJ Webb is a Linux Hobbyist and Research Coordinator. He enjoys fishing, hot rodding, and spending time with his kids and wife. He thanks Mike Ferarri for his mentorship.





GUIDELINES

The single rule for an article is that **it must somehow be linked to Ubuntu or one of the many derivatives of Ubuntu (Kubuntu, Xubuntu, Lubuntu, etc).**

RULES

• There is no word limit for articles, but be advised that long articles may be split across several issues.

• For advice, please refer to the **Official Full Circle Style Guide:** <http://url.fullcirclemagazine.org/75d471>

• Write your article in whichever software you choose, I would recommend LibreOffice, but most importantly - **PLEASE SPELL AND GRAMMAR CHECK IT!**

• In your article, please indicate where you would like a particular image to be placed by indicating the image name in a new paragraph or by embedding the image in the ODT (Open Office)

document.

• Images should be JPG, no wider than 800 pixels, and use low compression.

• Do not use tables or any type of **bold** or *italic* formatting.

If you are writing a review, please follow these guidelines :

When you are ready to submit your article please email it to: articles@fullcirclemagazine.org

TRANSLATIONS

If you would like to translate Full Circle into your native language please send an email to ronnie@fullcirclemagazine.org and we will either put you in touch with an existing team, or give you access to the raw text to translate from. With a completed PDF, you will be able to upload your file to the main Full Circle site.

REVIEWS

GAMES/APPLICATIONS

When reviewing games/applications please state clearly:

- title of the game
- who makes the game
- is it free, or a paid download?
- where to get it from (give download/homepage URL)
- is it Linux native, or did you use Wine?
- your marks out of five
- a summary with positive and negative points

HARDWARE

When reviewing hardware please state clearly:

- make and model of the hardware
- what category would you put this hardware into?
- any glitches that you may have had while using the hardware?
- easy to get the hardware working in Linux?
- did you have to use Windows drivers?
- marks out of five
- a summary with positive and negative points

You don't need to be an expert to write an article - write about the games, applications and hardware that you use every day.





When it comes to music CD ripping, Linux has a lot of choice: Asunder, Sound Juicer, RipperX, Abcde, Ripit, Ripoff, and Goobox just to name a few. Choice is one of the great things about Linux, but it can be a bit daunting if you're new to Linux and just trying to do a particular task. If you're new to Linux, I could just recommend using Banshee to rip music CDs and leave it at that. Besides being a music playing/cataloging monster, Banshee can rip CDs, lookup

artwork, show related Youtube videos, share audio over UPnP, and fix broken metadata. It's not quite the Emacs of audio players, but it's pretty close.

Ripping a CD in Banshee is simple, just select the CD from the left window and click the Import CD button in the top right of the Banshee interface. If you want to select only particular tracks, simply check/uncheck the tracks you want/don't want. Banshee automatically does a CD database

lookup to help fill in most metadata.

Banshee is flexible but not every option is easy to find. By default, Banshee rips music at a relatively normal 192Kbs bitrate. The option to change which bitrate Banshee rips at is hidden among drop-down menus: Edit > Preferences > Source Specific > Source (change this from Music to Audio CDs)

Now you can choose what you want to encode the ripped WAVs with by selecting the options in the

import format drop-down. If you like free lossless audio, choose FLAC. For maximum compatibility across media players, I set the import format to MP3 (Lame Encoder). When you change from FLAC to MP3, you also enable the Edit button beside the Import Sources. Clicking on Edit enables you to change the bitrate.

Banshee sometimes grabs artwork while you're playing your ripped media, but it doesn't automatically insert artwork into metadata when you rip a CD. If you use another program that doesn't

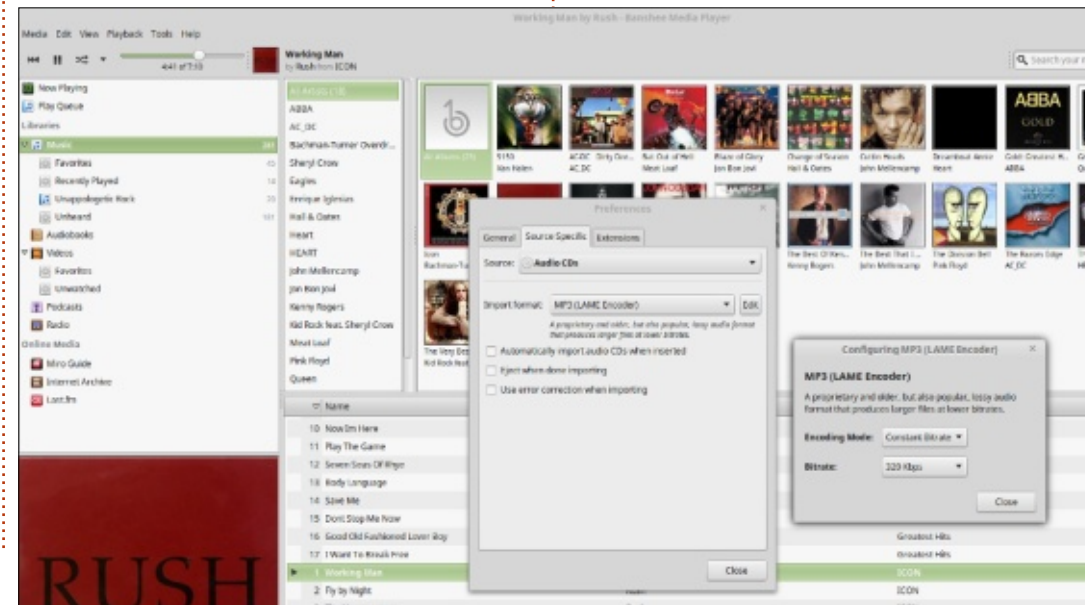

automatically grab artwork, you won't see any artwork. If you've followed Linux Labs for a while, you'll know I'm a big fan of KODI. KODI likes artwork to be embedded into the music metadata (ID3 tags).

There are a number of ID3 tagging programs for Linux, but EasyTag is one of the most comprehensive ones. Adding artwork is a tiny bit tricky, there's no automatic art lookup, but you can add artwork for: the song icon, the front cover, the back cover, the leaflet page, the CD itself, the lead artist, the artist, the conductor, the band/orchestra, the lyricist, the recording location, even the band logo. I normally just add front-cover art.

To add art, first select the artist on the left side, and select the song you want the artwork for in the middle. On the right hand side, select the Images tab (Common and Images under ID3 tag). Next click the + to add images (1), this will open the file dialog window so you can find the cover art on your file system. EasyTag automatically assumes you want to add the front cover, if this isn't the case, double-click on the selected image to

open the Image Properties. From the Image Properties window, you can choose the type of art the image represents.

This process is simple enough, but it adds the artwork for only one song. To add the artwork for all the songs on the album, simply shift+click or ctrl+click on each song to select them, and click on the painting icon (2) in the bottom right of the ID3 tag > Images Window. If you hover over the icon long enough, the following tooltip appears: "Tag selected files with these images."

Songs where the metadata has changed appear in red (not pictured). This helps differentiate between songs with altered metadata (red) and songs without (black). To save the song metadata, click the 'save changes (3)' to selected songs' icon in the top middle of Banshee (hint: it looks like a box with a down-arrow)

This is a rather simple workflow:

CD ripping program > ID3 tag editor

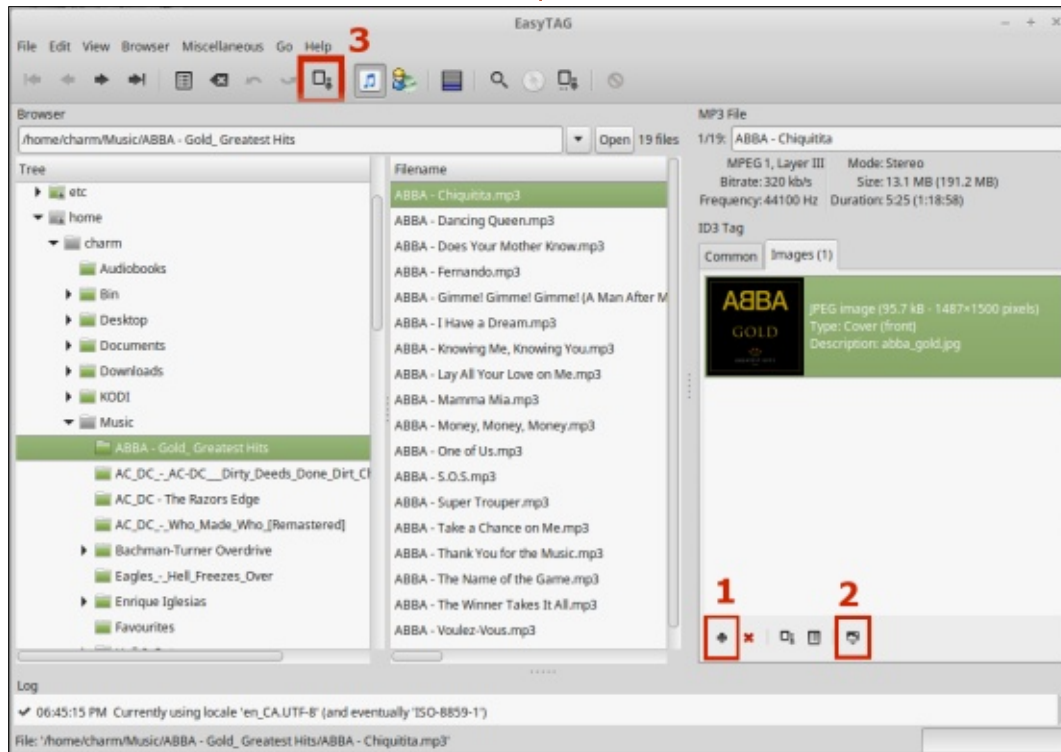

I use Banshee and EasyTag most of the time, but the odd time when I run into trouble with CD lookups, I try one of the alternatives like RipperX. RipperX has a much simpler interface, it follows the *NIX philosophy of doing one thing and doing it well. If you're more into working on the command-line, abcde is a good alternate.



Charles is the author of Instant XBMC, and the project manager of a not-for-profit computer reuse project. When not building PCs, removing malware, and encouraging people to use GNU/Linux, Charles works on reinventing his blog at <http://www.charlesmccolm.com/>.



UBUNTU DEVICES

Written by Ronnie Tucker

Nextcloud

Something a bit different this month. Not an Ubuntu Touch device, but a thing called Nextcloud which is a device to let you host your own files. It, of course, uses Ubuntu.



The **Nextcloud** Box consists of a hard drive and a case, complemented by a Raspberry Pi 2 or a similar credit-card sized computer (note: not supplied). The pre-configured, easy-to-use platform handles file storage and syncing, communication and more, requires no maintenance, and enables users to install more functionality through apps like Speed, OpenHab and Collabora Online. The box offers 1TB of storage at the price point of Eur 70. For information on where to buy please visit nextcloud.com/box

Key WD components including the WD PiDrive and SanDisk SD card deliver a device with the flexibility and openness to enable learning and experimenting, with easy installation and allowing replacement of components, and adding functionality and capabilities like more storage space, networking interfaces and other addons.

The base with Ubuntu Core enables the device to act as an extensible IoT gateway at home,

adding functionality and controlling other devices and connecting them with their owner while keeping the user secure through automatic, unattended updates.

The Nextcloud software empowers users to sync and share their data while remaining in control and accessing and collaborating through a range of devices and platforms, from browsers and mobile phones to desktops and laptops. The

federation capabilities make it possible to share among users on different Nextcloud servers, participating in and creating a network beyond the single device.

For more information on the product, please visit: nextcloud.com/box





BOOK REVIEW

Written by Greg Walters

Electronics For Kids



Electronics For Kids - Play With Simple Circuits and Experiment With Electricity!

by Øyvind Nydal Dahl

No Starch Press
ISBN 978-1-59327-725-3
July 2016
328 Pages

When I first got this book, I was curious just how much was being discussed about Electricity and Electronics. I was pleased that its contents range from the simplest “What is

Electricity?” to a LED-based reaction game. This book covers things like Resistor Colour codes, Ohm’s law, Soldering, Breadboards, making your own motor from scratch, and much, much more.

I was very happy to see that Øyvind states in the introduction “Whether you’re 8 or 100 years old, as long as you’re curious and have a playful spirit, this book is for you.”, and I can’t agree more. Having been in the situation of trying to teach basic electronics more than once, I wish that he had written this book years ago. Some of his analogies are startling in their simplicity – while explaining the subject completely.

Each project starts with a shopping list, a list of tools (if needed), very detailed instructions and explanations, and ends with a “what if it doesn’t work” troubleshooting section.

I have to give this book a full 5 stars. If you are curious about electricity or have a kiddo who is, this book is a must have for the

bookshelf. All of the projects are safe and very inexpensive. Many can be completed using items around the house.



TABLE OF CONTENTS

- Introduction
- Part 1: Playing With Electricity
 - 1: What is Electricity?
 - 2: Making Things Move With Electricity And Magnets
 - 3: How to Generate Electricity
- Part 2: Building Circuits
 - 4: Creating Light With LEDs
 - 5: Blinking A Light For The First Time
 - 6: Let’s Solder!
 - 7: Controlling Things With Electricity
 - 8: Building A Musical Instrument
- Part 3: The Digital World
 - 9: How Circuits Understand Ones And Zeros
 - 10: Circuits That Make Choices
 - 11: Circuits That Remember Information
 - 12: Let’s Make A Game!
- Handy Resources



I remember years ago when Windows was trying to integrate Internet Explorer (IE) into Windows so you couldn't remove it without breaking the operating system. Well, Windows 10 is at it again. With OneDrive. Microsoft (MS) has been the big player in the computer world and its goal is to control the industry. MS knew when the Internet was coming of age that it would take over the way mankind did business and communicate with one another. They wanted to be the top dog with IE browser, but that didn't happen. Now the big thing today is cloud storage and they want to be top dog with their OneDrive, but that is not happening. We have DropBox, Google Cloud and many others competing with them.

The Question is, have you tried to remove OneDrive? You will see Windows 10 OneDrive is built in. The connections are so tight, in fact, that OneDrive has its own node in File Explorer; with no obvious way to remove it. But the options to disconnect OneDrive are there if you know where to

look, and if you go to the link it will tell you how to do this. But be warned that you have to make a simple registry edit. Any time you get into the registry you can break things.

Okay, I am going to tell you a little secret. I have a great workaround for this problem, I don't use Windows because I don't like Microsoft's tactics, I use Linux. I do keep a copy of Windows on my laptop for odds and ends, but I use Linux as my main Operating System (OS).

I hear people say, Linux is too techie for me. That is not completely true. There is a learning curve in using a different OS, but you can do most everything in a Graphical User Interface (GUI) just like Windows, but you have more control over what you do, and Linux is not trying to take over the world and shove things down your throat and force you into using things you don't want or need. And just a little side note, you have different choices to choose from when it

comes to GUIs.

There is always a reason a company does things, and it is always for the benefit of the company. This just stands to reason. Have you ever asked why MS started giving away Windows 10? Most Linux distributions are free and MS knows this and they also know that Linux is becoming very popular. Just check out Distrowatch. The number of Linux users today is getting close to 87 million according to Linux Counter. My feelings are MS wants to make sure Windows OS doesn't lose ground in the number of users. We know that there are many more Window users in the world than Linux users, but it isn't about numbers. Linux users use their OS because they know it is better than what MS is offering. Yes, Windows has its place but it's not on the desk of a Linux user.

There are many people using tablets and phones that don't even give it a second thought that they are using Linux when they fire up their Android device. And we can't

talk about OSs without mentioning Apple's OS. Now, to make myself clear, I am not an Apple guy so I can't say anything bad or good about it. The only reason I have never used it was the cost of ownership. I felt that if I went with Apple I would have to go all the way, iPad, iPhone, iEverything, and I was afraid I would run out of money. From what I know about the early days of the Macintosh's OS, it was a lot like the Atari ST and TT computers. The Mac's OS came along in 1984, and Atari ST and TT OS were built on TOS. TOS was Atari's answer to DOS but when MiNT came along in 1989 (not to be confused with Linux Mint OS of today), it added a nice GUI that looked a lot like Mac's OS in the earlier days so I went in that direction.

Seeing that I grew up on this OS, let me give you just a little history on MiNT. It was developed by Eric Smith, who was trying to port the GNU library and related utilities on the Atari ST TOS. But the funny part was it was easier to add a Unix-like layer to the TOS

than to patch all of the GNU software, and MiNT began as a TOS extension to help in porting. I think it was back in 1990 that the new Kernel got started or at least it was building traction with other contributors to this work. What came about was the ability to do multitasking in a Graphical Environment Manager (GEM). Don't you just love these Acronyms? So it was no longer called just TOS, but MultiTOS and was installed using a floppy disk.

Okay, that's enough history. I did this to show you how far we have come with OSs and we ain't done yet.

I mention two things above, 'Unix' and a 'Kernel,' and thought I would make these clear to those who might not know what I am talking about. First, let me explain what Unix is and then what the Kernel has to do with the OS.

First, Linux is a Unix-like OS, but the Kernel is different. For now, just think of the Disk Operating System (DOS) in earlier computers as the underlying workings of the early Windows OS. Windows 98 was the last version to run on top of DOS. I read somewhere that

Windows NT 3.1 was the first non-DOS based OS. DOS was an early OS where Unix was an early OS as well. There are Unix OSs still in use today, but they have grown just like Linux. BSD is one that comes to mind and is in the list of Distros at Distrowatch. But it is not pure Unix and is referred to as Unix-like. Apple's OSX. the X is for 'graphical Unix OS' that was developed by Apple Inc. Nov. 15, 2010. I got this off the Internet because like I said earlier, I don't know much about Apple.

Every good Linux user should know that the Linux Kernel is the heart of Linux and was developed by Linus Torvalds and thousands of others.

This next tidbit is for the upcoming programmers. The first programming language that I learned (and I was not very good at it) was assembly language. This was the first computer language that was used to develop Unix. It was back in 1969 and was done at Bell Labs. Later development was changed to the C language.

History tells us a lot about what we are using today. I could have started this article out by saying;

'In the beginning there was Unix and then DOS came along. And then came so much more.' And maybe we should end this article by answering a few questions.

Is Linux Unix?

Is Windows Unix?

And what is Linux?

Let me start out by telling you what Unix is. Unix is a registered trademark. This means that the code is not free. There are various companies that sell and have sold code that was derived from the original system. Some examples are Solaris, HP-UX, AIX, and you can also see Evolution of Operating systems from Unix for more information.

This next statement can be found on the Internet by asking; what is Unix used for? Unix, multi-user computer OS, is widely used for Internet servers, workstations, and mainframe computers. It was developed by AT&T Corporation's Bell Laboratories in the late 1960s as a result of efforts to create a time-sharing computer system.

Okay, with that out of the way,

let's move on to the question, Is Linux Unix? Linux is the kernel that runs the OS. Or maybe I could say it this way. Linux is the OS kernel that was and is being designed like Unix's Kernel. That's where we get the saying 'Unix-like OS'. It does not use the Unix Kernel but it uses the Linux Kernel. So, to answer this question, I would have to say, Linux is not Unix. As many of the tools outside the kernel are part of the Gnu project, such systems are often known as GNU/Linux. Gnu is not Unix, with means Gnu isn't based on Unix original code, not that Gnu doesn't want to implement Unix spec. I could carry this further but I think you get the point.

Next question. Is Windows Unix? Just like Linux is referred to as Unix-like, so we find Windows in that same category. It is Unix-like. In fact, we can include all these OSs: Mac OS X, Android, IOS, Chrome OS, and Orbis OS used on the PlayStation 4. We could also include all the firmware that is running on your routers. Every one of these OSs is considered Unix-like. So to answer this question I will have to say Windows is not Unix.

MY OPINION

For the last question, "What is Linux?" We already said it was Unix-like, and we also said it was a computer OS, but we didn't say it was assembled under the model of free and open-source software development and distribution. We already mention the heart of Linux is its kernel. The first release of Linux was on October 5, 1991, by Linus Torvalds. Linux has come of age because of the many ways it is used today. Linux is showing up on device after device, and one of the reasons is the open-source software development and distribution. This is going to keep growing because of this reason.

There are so many that have not tried Linux on the desktop because Windows comes preinstalled on most computers. You need to special order one with Linux but someday this all might change.

THE OFFICIAL FULL CIRCLE APP FOR UBUNTU TOUCH

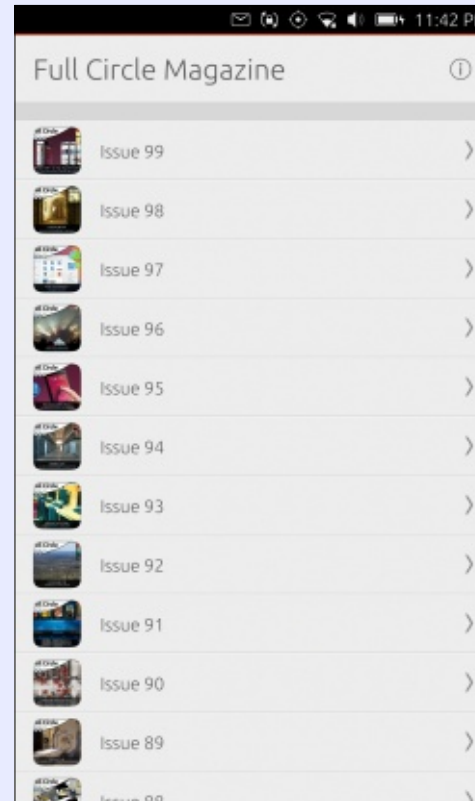

Brian Douglass has created a fantastic app for Ubuntu Touch devices that will allow you to view current issues, and back issues, and to download and view them on your Ubuntu Touch phone/tablet.

INSTALL

Either search for 'full circle' in the Ubuntu Touch store and click install, or view the URL below on your device and click install to be taken to the store page.

<https://uappexplorer.com/app/fullcircle.bhdouglass>

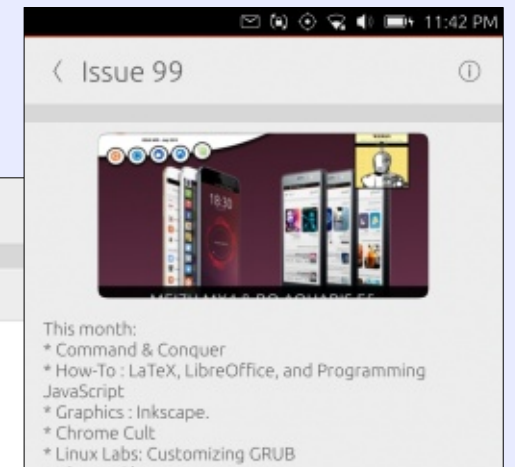
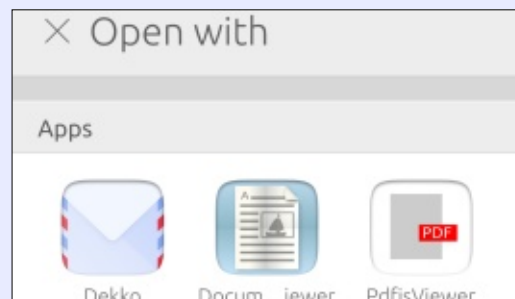



SYD'S PC MUSEUM

Just went up to see Syd Bolton's computer museum. It was a wonderful article and his museum site really brought back memories as I had been using a lot of those machines over the course of my work history since 1971. Had to send him some feedback on the Amiga's and the Commodore 128 that we used for personal use and a business. It is a real touch of nostalgia to know of all of these computer changes, and to have seen them first hand when we worked with new equipment being brought into the workplace. My first computer at home was the Commodore 128 and when I left my photo position with my former company to open a photo studio, I immediately moved to the Commodore Amiga 500, 2000 and 2500 to run a business. I can easily remember when computers took up rooms with multiple keyboard operators creating punch cards that were then fed to large reels of tape. Far cry from what we have today and certainly a lot less headache now. Having seen all of

this change, it does make you more comfortable flipping back and forth from Android devices, to Windows OS versions, to Linux OS distributions. When you get the bug, it kind of spurs you to learn even more and fool around with everything.

Thought you would want some feedback on this article since I enjoyed it so much, and I went right to his site based on your link. Fun!! I have personally used IBM keyboards connected as slaves to the mainframe for data entry, Macintosh SE (B&W), Color Mac, Amiga 500, 2000, 2500, Kaypro, Osborne, Microsoft DOS and Windows 3, 3.1, 95, 98, 98ME, 2000, XP, Vista, Win 7, 8/8.1 and now 10, and its Anniversary update. I did use the IBM Windows version for a while as well, before it folded. Have used Ubuntu Linux since 7.04, and, over the years, have installed about 8 different distributions to see how they worked. I am currently using Linux Mint Sarah on two very old machines. Working quite nicely with them. I also currently have

two Windows 10 portables and two Windows 7 workstations. I love your magazine and read it faithfully.

Brian Hartnell

GNU CASH

I read the GNU Cash review (FCM#113). I have used it for several years as my personal accounting software but don't use a lot of its features. I just don't have need of them.

Every year, my accountant wants a list of any accounts and their entries that might be deductible. Every year, I have to fumble around and try to figure out how to get the report that I want. Reports is one feature that I do use and wish was easier to use.

I recently took a look at Turbo Cash – but could never understand how to get started with it, so I deleted it.

Harold Williams

Join us on:



goo.gl/FRTMl



facebook.com/fullcirclemagazine



twitter.com/#!/fullcirclemag



linkedin.com/company/full-circle-magazine



ubuntuforums.org/forumdisplay.php?f=270

FULL CIRCLE NEEDS YOU!



Without reader input **Full Circle** would be an empty PDF file (which I don't think many people would find particularly interesting). We are always looking for articles, reviews, anything! Even small things like letters and desktop screens help fill the magazine.

See the article **Writing for Full Circle** in this issue to read our basic guidelines.

Have a look at the last page of any issue to get the details of where to send your contributions.

ENTROWARE

It was interesting to see you asking about System 76 (see interview this issue) because they were one of the companies that I came across when I was looking for a new laptop earlier this year.

During my research, however, I found a relatively new company based in Liverpool (UK) called Entroware. I ended up buying a 13" laptop from them for about £500 that was pretty much custom made to the specs I wanted.

If you want to find out more about what they do, this is the link: <https://www.entroware.com/store>

Apart from the fact that I am more than happy with my Apollo laptop, so much so that I intend to buy one for my wife for Christmas, I have no connections with the company or any ulterior motive to promote them.

John

SETUP OF YOUR STARTUP

It would be great to see a series of articles discussing the complete setup of a startup business with Linux.

I'm sure a lot has already been written on this, but it would be great if you could bring together a special issue or a series of articles that focuses on everything a startup business would need. From, say, an LDAP server, to setting up client laptops and desktops, and all kinds of server software and client software, that a startup can use to be completely free of Windows and Office.

Maybe you can have people write in about their Linux setups in their small business?

Jdog Zilla



Over the past couple of years, we've had a lot of people coming to our refurbishing project asking for computers to run KODI on. Whether it's prompted by rising television costs, the low cost of Android TV boxes, Internet-specific streaming shows, or simply being able to better choose the content, programs like KODI and PLEX are changing the way people consume media.

Whether you're using KODI on an Android box or on a PC, there are a great number of things you can do with KODI. This new column is dedicated to the interesting tips, tools and add-ons available for KODI. Each month, we'll look at several useful KODI tips, add-ons or tools.

The first tip, KODI's System Events, comes courtesy of Team

KODI's Nate Betzen who pointed out this tip in an episode of Kord Kutters (which, by the way, is available as an Add-on in KODI). The System > Events sub-menu option is useful when you're trying to troubleshoot problems with KODI. If you've copied some media to KODI, and KODI isn't properly scraping it, chances are you'll see it in Events.

In the screenshot, two television shows, Homeland s01e09 and Homeland s01e07, have failed to scan to the television library. The shows are named correctly: <showname> season and episode. The problem in this case is that they're not in a Homeland named sub-directory. Events won't tell you this, but it will give you an idea of what might be causing your problems.

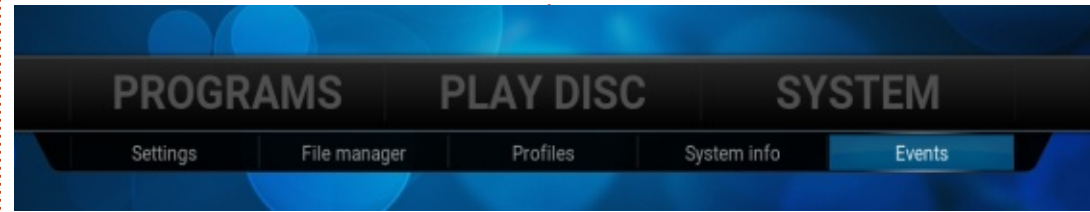
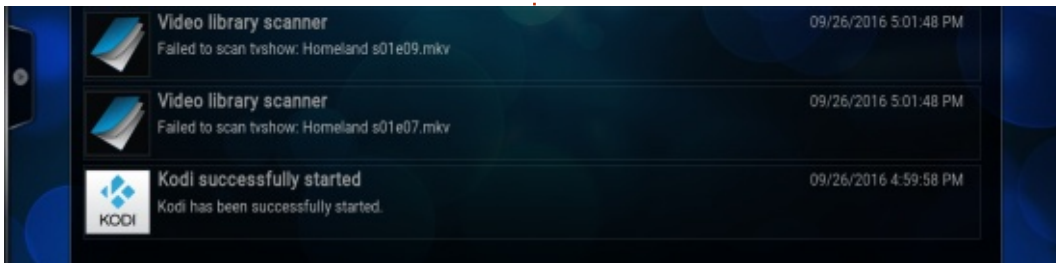

Finding the Events sub-menu is a bit tricky, it's just below the word System when you click System in the main menu (provided you're using the default Confluence KODI skin).

Want to watch television shows and movies, but do it legally? This second tip, the CrackleR add-on in the KODI repositories, lets you watch a selection of mainstream movies and television shows without subscribing to anything.

The catch? Advertisements appear at certain points within each movie or television show. Crackle.com, the site the feeds come from, is owned, surprise, surprise, by Sony Pictures Entertainment. Sony has partnered with over 20 studios to help bring more content to Crackle. Crackle also features some original programming content.

To install CrackleR, click Video > Add-ons > Get More, and select the

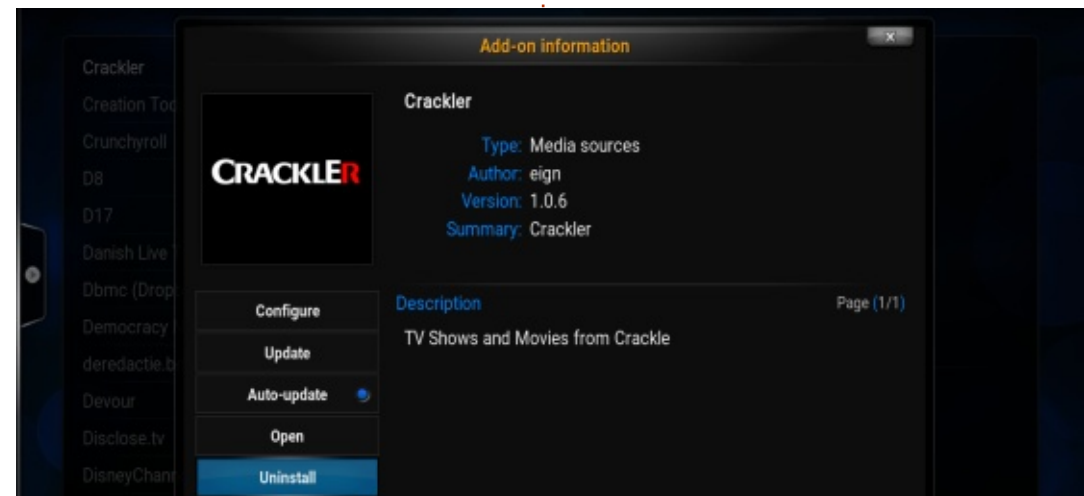

CrackleR add-on.

If you regularly add media to your KODI system, this third tip will be useful to you. The XBMC Library Auto Update will automatically update your content every 4 hours. This time can be adjusted in the add-on configuration. The Auto Update add-on can also be configured to “clean” the library (though this is not on by default). If you remove (or rename) media from KODI, setting the XBMC Library Auto Update to clean will remove content you’ve removed from your media library.

Earlier, I mentioned how Events showed us that the Homeland episodes were not being added to our media library. To fix the issue, we added a folder called

Homeland under our tv shows folder and moved the Homeland episodes to that folder. When we installed the XBMC Library Auto Update add-on, it ran for the first time and correctly scraped the Homeland TV show information for all of the Homeland shows.

If we moved or changed the content, the library would adjust accordingly the next time Auto Update runs (4 or so hours). Install the XBMC Library Auto Update add-on by clicking on Programs > Get More > XBMC Library Auto Update.

The last tip for this month is a bit more fun if you’ve populated your library with movies and television shows. The Movie Quiz add-on can be found by clicking

Programs > Get More > Movie Quiz. Movie Quiz goes through all the movie and television content stored on your computer and asks you questions based on your collection. This is a great add-on when you get a group of movie buffs all in one room.

That’s it for this month’s KODI Room. Please let us know if you find this new column useful and if there’s a tip, add-on or feature in KODI you want to see here, feel free to message me on Twitter: <https://twitter.com/chaslinux> or Google+: <https://plus.google.com/+chaslinux>.



Charles is the author of Instant XBMC, and the project manager of a not-for-profit computer reuse project. When not building PCs, removing malware, and encouraging people to use GNU/Linux, Charles works on reinventing his blog at <http://www.charlesmccolm.com/>.





Q&A

Compiled by Gord Campbell

If you have a Linux question, email it to: misc@fullcirclemagazine.org, and Gord will answer them in a future issue. Please include as much information as you can about your query.

Q Which VPN do you recommend for 16.04 LTS when I'm connected to an open WiFi hotspot?

A Actually, I don't recommend a VPN at all. If you have a computer at home when you are on the road, Teamviewer is my suggestion. Easy to set up, reliable, secure, free, cross-platform, what's not to like? OK, it's proprietary.

Q I have multiple ssh servers within my home network. Is there a way to specify which one of the many ssh servers from my single IP that I want to access?

A (Thanks to *efflandt* in the Ubuntu Forums) You would need to configure each ssh server, except one, to some port other than port 22 and specify the port when connecting (or in `~/.ssh/config` of client computer) and in port forwarding on your router. For example, Linux based ip-cop uses port 222 for its sshd, but you can configure sshd for most any port not being used.

Q I have a large database of text files. What search engine do you recommend?

A (Thanks to *TheFu* in the Ubuntu Forums) Try `recoll`.

Q How can I disable the touchpad?

A (Thanks to *Bucky Ball* in the Ubuntu Forums) Try Settings, Mouse and Touchpad, and disable the touchpad.

Q My computer has an Intel Pentium J2900 processor, and it completely locks up from time to time. How can I fix this?

A That is one of many "Bay Trail" processors. For the full list: http://ark.intel.com/products/code_name/55844/Bay-Trail#@All

(Thanks to *QLee* in the Ubuntu Forums) The "Bay Trail" processors and motherboards that have them

embedded at the present time often need to disable some of the power saving features in order to not have those random freezes. (The kernel developers are working on the problem.) Some BIOSes have a setting where you can disable the `cstates` and you could do it there if your MB will allow it. Remember what you have done so you can remove it once they deal with the problem.

Otherwise, you can change a GRUB parameter. In the file `/etc/default/grub` change the line

```
GRUB_CMDLINE_LINUX_DEFAULT="quiet splash"
```

to

```
GRUB_CMDLINE_LINUX_DEFAULT="quiet splash intel_idle.max_cstate=1"
```

Then:

```
sudo update-grub
```

TOP QUESTIONS AT ASKUBUNTU

If you are nervous about clicking on a short `goo.gl` URL, you can get information about it quite easily. Copy the URL, paste it into your browser's address bar, and add a plus-sign. Now `goo.gl` will tell you where it goes, as well as statistics about its use. (Thanks to `askleo.com` for the tip.)

* I forgot my username, how do I get it back?

<https://goo.gl/ftVTxg>

* What are possible uses of the `exec` command?

<https://goo.gl/YYV4Qn>

* Battery Charged at 97%

<https://goo.gl/4n86Tk>

* `chown: invalid option -- 'i'` Try '`chown --help`' for more information

<https://goo.gl/ZbVKyV>

* SSH to home computers

<https://goo.gl/LIHUJr>



* New Android Studio IDE not supported in Linux?

<https://goo.gl/CBBLqK>

* Can I boot a Live USB fully to RAM, allowing me to remove the disk?

<https://goo.gl/zPi2a4>

* Is 'apt-get' deprecated?

<https://goo.gl/2hfrwQ>

* How to prevent a new user from doing anything dangerous?

<https://goo.gl/KZRCOr>

TIPS AND TECHNIQUES

Sometimes it's not Linux

One of the simple games I enjoy is Freecell, but recently it became difficult to play.

When I tried to drag a card, it acted like I was going click, click, click, click at high speed, and cards were flying everywhere. As it got worse, I said to myself, "this is a hardware problem."

Fortunately, I have a good supply of spare mice, keyboards, even webcams. I swapped the

mouse, and I could drag a card the way I wanted to.

Then I got a message that I was offline. My standard solution is to reboot, but that didn't get me online. I aimed a flashlight at the Medusa's nest of cables behind my monitor, and learned that I had inadvertently unplugged my Ethernet cable. As soon as I plugged it back in, I was online.

So, two problems, two problems solved -- and neither of them were caused by Linux.



Gord had a long career in the computer industry, then retired for several years. More recently, he somehow found himself "The IT Guy" at a 15-person accounting firm in downtown Toronto.



What's the story behind System76?

System76 started ten years ago with a goal to make high-quality computers born to run Linux, and that respected the user. The name is based off of the year of U.S. independence, 1776, reinforcing the idea of freedom. It has since grown immensely, now shipping laptops, desktops and servers all over the world, with a great team supporting them.

System76 focuses extensively on ensuring its hardware works seamlessly for users and the whole experience feels cohesive. We work to build a complete product, down to little touches like the super key featuring the Ubuntu logo vs the Windows key you see shipping on Linux laptops from other vendors.

What made System76 even consider selling hardware with Linux, and why Ubuntu?

GNU/Linux and the open source community deserved a high-

quality manufacturer. And we believed that the benefits of Linux and the tools it offered were under-served. We also felt that with a strong company and customer support team backing Linux and promoting the open source tools available, we could empower the masses to become the creators of their environment rather than simply consumers. Most importantly, Linux would receive the attention and focus on hardware/software support that it deserved.

Red Hat and SUSE were tested, but weren't adopted due to various factors. A distribution called "Yoper" was almost adopted, but ultimately passed over due to a lack of commercial support. Finally, Ubuntu was selected, although it was decided over the course of a few months. The community, OEM support as necessary, accessibility for non-techies, and the consistent user experience the distro provided, were, ultimately, the deciding factors.

Carl has a more detailed blog post about the beginning of the company:

<http://carlrichell.com/post/2611107120/how-system76-began>

Does System76 have any plans to offer Linux alternatives such as Mint? Or, better still, let people choose a distro while buying.

Having a variety of Linux distros for users to choose from was a feature that the founders investigated exhaustively. In the end, they realized that the best way to spread Linux (and FOSS), was to eliminate any potential for decision overload that could occur with requiring new Linux-users to choose among all the different distros.

It was ultimately important for System76 to deliver a positive, holistic experience that would represent the open source community in the best possible light. In order to do this successfully, we deduced that one

distribution needed to be chosen in order to thoroughly conduct proper firmware testing, support and compatibility for a truly seamless experience.

Still, the distro debate is ongoing, and very passionate. Even within our own office, each member of the staff has their own flavor of choice. For System76, our end goal is to empower the maker movement with the highest quality hardware, manage firmware and compatibility testing so that users don't have to, and grow the network of Linux supporters by introducing everyday users to the power of open source software.

Having said that, we are looking at providing all the documentation that is generated whilst we are working on hardware support, device drivers, etc., to our customers and fans. Currently, testing every distro would stretch us too thin. With that documentation, the communities around these different distros could help test compatibility and support. That would allow us to

provide a list of distributions that we know are well supported on our hardware. Once that is in place, who knows?

Does System76 intend to open a European/non-US shop(s) in the near future?

We don't have any "shops" at the moment, our only physical location that we have is our office here in Denver. This is largely because our machines are custom built to order online and don't warrant a physical location. However, we do ship all over the world and will continue to do so, you can see specifically where we ship here:

<https://system76.com/shipping>

Or even sell System76 hardware through online retailers such as Amazon?

Selling our products through other retailers, either online or brick-and-mortar, may be a possibility. But we like ensuring the experience is a positive one, and upon buying a machine you have an account with a dashboard that allows you to talk to our team about your device. This is a really powerful tool, that facilitates

conversation with our staff, and really makes what has become a real differentiator between us and other OEMs. I would be worried about losing that strong relationship and trust with our customers by inserting a third party there.

For folks outside of the US looking to buy System76, what are the implications with regards to warranties, returns, etc?

If we ship there (see question about shipping above), then you get the same shake as anyone else who orders. We have many customers outside of the U.S., all over the world in fact. We work very hard to provide the same level of service and support to them as our U.S. customers. We are very proud of all the places we've sent System76 devices to, and hope to continue to grow to be able to serve customers in even more places in the years to come.

If you want to see if we ship to your country, check out <https://system76.com/shipping>

Do you have a team who are always working on the support documentation?

What a great question, and well timed too! In the past we have worked hard on providing documentation through many avenues to our customers. But, as of late, we have undertaken a really fantastic project that will not only serve our customers, but everyone in the Linux community.

We have been working on <http://support.system76.com> - which features a number of tutorials, support docs, and articles that I think are great resources. We're still at the beginning of this initiative, but these docs are open source and you can contribute to them on GitHub, simply by clicking the "Edit on GitHub" button, whilst viewing the article. Also, anyone can create an article, so we are looking for other contributors. We would like for this to be a great support resource for all Linux users, not specifically just System76 customers.

Is there a way to chat with System76 tech/ reps via the site rather than a phone number?

Yes! You can live chat with us through the website at: <https://system76.com/contact>

Any plans to make 13" laptops for us travellers?

Both Carl and myself (Ryan) are big fans of this form-factor. Right now I use the 14" Lemur and am in love with it. It is light, powerful, and a really great machine - worthy to tag-along with any traveller (I travel quite a lot between Denver, Kansas City, and various conferences). I would recommend this to someone who wants an awesome travel companion today.

What about docking stations? Not a USB one, but a proper one like Dell/Lenovo do.

We are doing extensive testing of USB docking stations for those who already have machines and want to use one. As for the future, we are working on this and I imagine we will have more to say on that front as our next generation of products is announced. We are very aware that many of our customers want this. We hear you, and we are working to make it happen.

Does System76 have any plans to make mini-PCs that could

be used for TV or desktop use?

How mini are we talking? The Meerkat is a very small PC that I use at home for an HTPC (to stream over stuff from my Plex server, as well as online content). It can be mounted to the back of a monitor or a television with relative ease.

If you are looking for a desktop that uses the least space possible, go for our all-in-one Sable. It is beautiful, and requires only the space needed for most monitors. In fact, even Mark Shuttleworth has commented on the beauty of the Sable before.

What about a phone? Would System76 be interested in making an Ubuntu phone?

What an interesting question (grin). We have looked at the possibility of making a phone and weighed doing this a number of times since the Ubuntu touch/phone/personal project was announced. We would certainly like to make a phone, but are watching and waiting for the platform to be mature enough to provide a stable and positive experience for our customers.

Is there anything in the System76 pipeline that you can tell us about?

We definitely have some amazing products in our pipeline, but unfortunately we can't talk about them in detail (yet)! Our R&D department has been producing some really awesome stuff in our new "secret lab". The end of the year through 2017 should serve to be a very exciting time for everyone who shares our desire for great devices running open source software. So I would ask everyone reading this to pay attention to what we're doing and follow us online!

Twitter: [@system76](https://twitter.com/system76)

Google+:
<https://plus.google.com/+system76>

Facebook:
<https://www.facebook.com/system76>

Thank you for taking the time to answer these readers' questions.

NEXT MONTH: WIRE DEVELOPERS

In case you didn't know: **Wire** (the messenger which has mobile and desktop apps that can do audio/video calls and text messaging) is now on Linux!

<https://wire.com/download/>

To bring you up to speed (basically a TL;DR): Wire runs on Android/iOS, Windows, Mac, Linux and in most browsers. As mentioned it can do audio/video calls. Even group calls/chats, but most important of all is that it uses full end-to-end encryption! It's also open source with it's code hosted on GitHub.

This is where you come in: is there anything you'd like to ask the developers of Wire? Maybe something about privacy, or upcoming features? Even if they use Linux. It's entirely up to you. Email you questions to: ronnie@fullcirclemagazine.org and I'll pass them along.

For more info on Wire's privacy: <https://wire.com/privacy/>

The logo for Wire, featuring the word "wire" in a lowercase, rounded, sans-serif font. A small "TM" trademark symbol is located at the top right of the letter "e".



The Ship: Remastered, a Steam Early Access game released on February 2016 for Microsoft Windows, Mac OS X & Linux, is a remake of The Ship which was originally released on July 2006 on Steam. Originally developed by Outerlight using Valve's Source Engine, the game is a first-person shooter playable with mouse/keyboard. The original game was later renamed The Ship: Murder Party.

The 2016 remake has been developed and published by Blazing Griffin and, as a Steam

Early Access game, it is still a bit buggy so be advised and play at your own risk. Personally, I've only run into a couple of problems and, for the most part, the game has run pretty smooth.

The Ship: Remastered is currently being sold for \$19.99 through the Steam Store and I was lucky enough to buy it for half of that price during a recent Steam sale. This is a fun game to play casually but it can also be embraced by more hard-core gamers. A recent June 2016 update titled World Leaders has

added a world politics rat pack of characters which includes Fidel Castro, Tony Blair, George Bush, Ronald Reagan, Hillary Clinton, Donald Trump and even Osama Bin Laden and Saddam Hussein. Being a U.S. citizen and having to (unfortunately) put up with the most embarrassing presidential campaign since as long as I can remember, it seemed like playing this game would be a good way for me to blow off some steam. I wasn't disappointed.

There are a number of choices given before you even start the game, such as Arcade, Join Cruise, Create Server (Cruise). You can also select what kind of game you want to play from among Hunt, Eliminate World Leaders, Hunt World Leaders, and many more. You can also choose the ship that you want to ride from about 6 different ones, and this choice will naturally affect the ship's map. I've tried playing the Arcade Mode which is played against the computer and, even on Medium difficulty level, this mode is pretty hard. I've joined other players via

the Join Cruise option which is basically joining someone else's server. I've had mixed results with this mode as might be expected. One time I had the game completely shut-down. Other times I've joined servers where I was the only other player besides the host, and I've joined other servers in which there were plenty of players which made it more fun, entertaining, and, as a result, it was also harder to win. Prior to beginning you also have the option to choose how long the game will last as well as a few other variables.

So, let's get on to what this game is all about. Although it's very much a first-person-shooter at its core, it's also very much of a survival game. There are two goals in this game, the first goal is to eliminate/hunt/kill a very specific opponent. However, on the flip-side, you're also being hunted by someone else (though realistically anyone else can target you), so this means you need to stay alive by any means necessary. With the exception of the World Leaders



game modes, it can be fairly easy to stay alive not only by finding good hiding spots but also by disguising yourself so that whoever happens to be hunting you has a harder time spotting you when you no longer look like the person they're after. While playing in one of the World Leaders game modes, it's literally impossible to hide since ALL clothing items are unusable which makes disguises useless. On top of that, with the exception of a few lesser known world leaders, it's way too easy to identify your quarry, and it's also easy for your opponent to identify you as well.

As soon as the game begins, you're given a "quarry" whom you're supposed to kill. The only problem is that you are also someone else's quarry, which means that while you're tracking down your target, someone else is tracking you down and trying to take you out. You begin inside a room in the cruise ship that I assume belongs to you; however, all open rooms are available to all players. In the room you'll find a bed in which you can sleep whenever you happen to be tired (though you can also sleep in other beds if necessary). Also, in the

room, you can look for various hidden items which includes various weapons, alternate clothing items (hats, pants, shirts, dresses, etc.), food, drinks, etc.

Besides having to kill your quarry, you're also expected to do other things to stay afloat such as eat, drink, socialize, sleep, use toilet, shower. Failing to do these things when your on-screen timer asks you to do so will have negative results. For example, if your sleep counter appears and demands that you rest a little, but you fail to do so, then you will literally fall asleep wherever you happen to be which makes you 100% vulnerable and easier for your hunter to hunt you. Likewise,



while tracking down your quarry, you are free to kill other players; however, any one of these kills will deduct money from you, while focusing on killing your own specific quarry will give you a large money reward. There are Non-Playable-Characters throughout the ship – including cops/security guards. If you take out a weapon in front of one of these NPCs, you will most likely have to go to court, and if you don't have enough money to pay the fine, you might also have to go to jail and serve some time. It is possible, however, to bribe the cops to look the other way if you have enough money to pay them off. If you do happen to land in jail, it might be a wise idea to take care of some of your daily needs such as eating, sleeping, showering, etc.

All in all, this is a fun game to play. It's basically an old game but this new HD remastered edition gives it a few improvements such as the graphics, and the World Leaders update adds some new characters as well. The cartoon-like graphics are pleasant to watch but not at all revolutionary. The soundtrack is good and the sound effects are pretty effective and sound somewhat realistic but

there is a lack of voice-acting. Game-play is pretty good and, given the many options from which to choose, this makes The Ship: Remastered a very flexible game. All sorts of players can find something worthwhile in this game but we should keep in mind that the game is still in beta mode. I definitely recommend this game, especially if you find it on sale.



MINIMUM SYSTEM REQUIREMENTS:

OS: Ubuntu 12.04 or higher
CPU: 2.0 GHz Quad Core
Memory: 4GB RAM
HDD: 6 GB HD space
GPU: AMD Radeon HD 7560D or Nvidia GeForce GT 730



Oscar graduated with a music degree from CSUN, is a Music Director/Teacher, software/hardware beta tester, Wikipedia editor, and active member of the Ubuntu community. You can email him at: 7bluehand@gmail.com



PATRONS

PATRONS

Bill Berninghausen
 Jack McMahon
 Linda P
 Remke Schuurmans
 Norman Phillips
 Tom Rausner
 Charles Battersby
 Tom Bell
 Oscar Rivera
 Alex Crabtree
 Ray Spain
 Richard Underwood
 Charles Anderson
 Ricardo Coalla
 Chris Giltane
 William von Hagen
 Mark Shuttleworth
 Juan Ortiz
 Joe Gulizia
 Kevin Raulins
 Doug Bruce
 Pekka Niemi
 Rob Fitzgerald
 Brian M Murray
 Roy Milner
 Brian Bogdan
 Scott Mack
 Dennis Mack
 John Helmers
 JT

Elizabeth K. Joseph
 Vincent Jobard
 Chris Giltane
 Joao Cantinho Lopes

DONATIONS

John Niendorf
 Daniel Witzel
 Douglas Brown
 Donald Altman
 Patrick Scango
 Tony Wood
 Paul Miller
 Colin McCubbin
 Randy Brinson
 John Fromm
 Graham Driver
 Chris Burmajster
 Steven McKee
 Manuel Rey Garcia
 Alejandro Carmona Ligeon
 siniša vidović
 Glenn Heaton
 Louis W Adams Jr
 Raul Thomas
 Pascal Lemaitre
 PONG Wai Hing
 Denis Millar
 Elio Crivello
 Rene Hogan
 Kevin Potter

Marcos Alvarez Costales
 Raymond Mccarthy
 Max Catterwell
 Frank Dinger
 Paul Weed
 Jaideep Tibrewala
 Patrick Martindale
 Antonino Ruggiero
 Andrew Taylor



CHA CHA CHA CHANGES

Our admin went AWOL for months, and I had no idea if/when the site would/wouldn't get paid. Initially the plan was to move the site and domain name to my hosting, but eventually I managed to track him down and get the FCM domain name, and site hosting transferred to me.

The new site is now up. **HUGE** thanks to **Lucas Westermann** (Mr. Command & Conquer) for taking on the job of completely rebuilding the site, and scripts, from scratch, in his own time.

The Patreon page that I've set up is to help me pay the domain and hosting fees. The yearly target was quickly reached thanks to those listed on this page. FCM is not going away. Don't worry about that.

Several people have asked for a PayPal (single donation) option, so I've added a button to the side of the site

A big thank you to all those who've used Patreon and the PayPal button. It's a big help.

<https://www.patreon.com/fullcirclemagazine>



HOW TO CONTRIBUTE

FULL CIRCLE NEEDS YOU!

A magazine isn't a magazine without articles and Full Circle is no exception. We need your opinions, desktops, stories, how-to's, reviews, and anything else you want to tell your fellow *buntu users. Send your articles to: articles@fullcirclemagazine.org

We are always looking for new articles to include in Full Circle. For help and advice please see the **Official Full Circle Style Guide**: <http://url.fullcirclemagazine.org/75d471>

Send your **comments** or Linux experiences to: letters@fullcirclemagazine.org
Hardware/software **reviews** should be sent to: reviews@fullcirclemagazine.org
Questions for Q&A should go to: questions@fullcirclemagazine.org
Desktop screens should be emailed to: misc@fullcirclemagazine.org
... or you can visit our **site** via: fullcirclemagazine.org



FCM#115

Deadline:
Sunday 06th Nov 2016.
Release:
Friday 25th Nov 2016.



Full Circle Team



Editor - Ronnie Tucker
ronnie@fullcirclemagazine.org

Webmaster - Lucas Westermann
admin@fullcirclemagazine.org

Editing & Proofreading

Mike Kennedy, Gord Campbell, Robert Orsino, Josh Hertel, Bert Jerred, Jim Dyer and Emily Gonyer

Our thanks go to Canonical, the many translation teams around the world and **Thorsten Wilms** for the FCM logo.

Getting Full Circle Magazine:

For the Full Circle Weekly News:



You can keep up to date with the Weekly News using the RSS feed: <http://fullcirclemagazine.org/feed/podcast>



Or, if your out and about, you can get the Weekly News via Stitcher Radio (Android/iOS/web):
<http://www.stitcher.com/s?fid=85347&refid=stpr>



and via TuneIn at: <http://tunein.com/radio/Full-Circle-Weekly-News-p855064/>



EPUB Format - Most editions have a link to the epub file on that issues download page. If you have any problems with the epub file, email: mobile@fullcirclemagazine.org



Issuu - You can read Full Circle online via Issuu: <http://issuu.com/fullcirclemagazine>. Please share and rate FCM as it helps to spread the word about FCM and Ubuntu.



Magzster - You can also read Full Circle online via Magzster: <http://www.magzster.com/publishers/Full-Circle>. Please share and rate FCM as it helps to spread the word about FCM and Ubuntu Linux.